

USER'S GUIDE

AP-750

Initial Setup



Preparing a Power Supply



Turning the Power On/Off



Using the Pedals



Using Headphones

Playing the Digital Piano



Selecting a Tone



Layering Two Tones (Layer)



Splitting Left and Right Keys (Split)



Using the Metronome

Changing Sound Reverberation and Ambiance



Using Sound Mode Effects (Hall Simulator/ Reverb and Surround)



Using Chorus



Adjusting the Sound Characteristics of the Acoustic Piano Presets (Acoustic Simulator)



Changing the Pitch in Semitone Steps (Transpose)

Recording Performances in Real-Time



Recording a Performance with the MIDI Recorder



Recording a Performance with the Audio Recorder

Check the Sound of Your Performance



Listening back to a Performance Immediately (Instant RePlayer)

Connecting with a Smart Device



Using the Dedicated App

Contents

Overview of the Digital Piano	EN-7
Part Names and Functions	EN-7
Preparation Before Playing	EN-10
Preparing a Power Supply	EN-10
Keyboard Cover	EN-11
Opening the Keyboard Cover	EN-11
Closing the Keyboard Cover	EN-12
Turning the Power On/Off	EN-13
Turning the Power On	EN-13
Turning the Power Off	EN-14
Adjusting the Volume	EN-14
Using the Supplied Wireless MIDI & Audio Adaptor	EN-15
Using Headphones	EN-16
Using the Music Stand	EN-17
The Top Panel of the Digital Piano	EN-18
Opening the Top Panel of the Digital Piano	EN-18
Closing the Top Panel of the Digital Piano	EN-19
Read This First (Basic Operations and Settings)	EN-20
Notation in this Manual	EN-20
Touch Button Operation	EN-21
Operation of the Touch Buttons Alone	EN-22
Touch Button and Keyboard Combination Operation	EN-23
Notification Tones	EN-28
Notification Tone Types	EN-28
How the Visual Information Bar Displays for Various Settings	EN-29
Piano Acoustic Setting and Demo Songs	EN-31
Selecting the Acoustic Setting Appropriate for the Installation Location (Piano Position)	EN-31
Playing the Demo Songs	EN-32
Operations Possible during Demo Song Playback	EN-32
Ending Demo Songs	EN-33
Playing	EN-34
Selecting a Tone	EN-34
Selecting a Single Tone	EN-37
Layering Two Tones (Layer)	EN-39
Splitting Left and Right Keys (Split)	EN-41
Splitting the Keyboard into Left and Right for Two-Person Performance (Duet)	EN-42
What is a Duet?	EN-42
Using the Duet Function	EN-43
Changing the Pitch Range	EN-44
Using the Pedals	EN-45
Adjusting the Position of Where the Half Pedal is Applied (Half Pedal Position)	EN-46

Using the Metronome	EN-47
Metronome On/Off	EN-47
Setting the Beat	EN-48
Setting a Tempo	EN-49
Adjusting the Volume	EN-50
Applying Effects to Sound	EN-51
Using Sound Mode Effects (Hall Simulator/Reverb and Surround)	EN-51
Turning on/off Hall Simulator/Reverb and Surround	EN-51
Selecting Hall Simulator/Reverb Presets	EN-52
Adjusting Applied Hall Simulator/Reverb	EN-53
Selecting Surround Presets	EN-54
Using Chorus	EN-55
Adjusting Brilliance	EN-56
Adjusting the Sound Characteristics of the Acoustic Piano Presets (Acoustic Simulator)	EN-57
Setting String Resonance	EN-57
Setting Damper Resonance	EN-58
Setting Damper Noise	EN-59
Setting Open String Resonance	EN-60
Setting the Aliquot Resonance	EN-61
Setting Pedal Action Noise	EN-62
Setting Key On Action Noise	EN-63
Setting Key Off Action Noise	EN-64
Setting Lid Simulator	EN-65
Adjusting Key Touch	EN-66
Changing the Volume Made by the Strength of Pressure Placed on a Key (Touch Response)	EN-66
Changing the sensitivity of Touch Response	EN-67
Adjusting the Timing of Key Press to Sound (Hammer Response)	EN-68
Adjusting Hammer Response	EN-68
Adjusting the Timing of Mute During Key Release (Key Off Response)	EN-70
Adjusting Key Off Response	EN-70
Adjusting the Pitch of Sound	EN-71
Changing the Pitch in Semitone Steps (Transpose)	EN-71
Transpose	EN-71
Fine-tuning (A-tuning)	EN-72
Tuning	EN-72
Shifting by Octaves (Octave Shift)	EN-73
Shifting Upper1 Part by an Octave	EN-73
Shifting Upper2 Part by an Octave	EN-73
Changing the Scale Tuning (Temperament) of the Keyboard	EN-74
Changing the Scale Tuning	EN-74
Setting the Scale Tuning Base Note	EN-75
Switching Stretch Tuning On/Off	EN-75

Selecting the Appropriate Setting for the Song or Scene to be Played (Scene) EN-76

Preset Scenes and User Scenes	EN-76
Calling Up a Scene	EN-76
Listening to the Sound Atmosphere of the Scene to Confirm (Scene Song)	EN-77
Creating Your Own Scenes (User Scenes).....	EN-78
Storing in User Scenes	EN-78
Songs that can be Stored in User Scenes (Scene Songs)	EN-79

Listening to Songs EN-80

Types of Data that Can Be Played Back	EN-80
Playing MIDI Data	EN-80
Switching to MIDI Recorder.....	EN-81
Selecting Songs for Playback from the Music Library	EN-81
Selecting a MIDI Recorder Song for Playback	EN-82
Selecting a USB Flash Drive Song for Playback	EN-82
Changing the Tempo	EN-84
Selecting a Playback Part	EN-85
Playing Audio Data (WAV, MP3).....	EN-86
Data that Can be Played Back	EN-86
Switching to Audio Recorder	EN-86
Selecting a Song for Playback	EN-87

Recording a Performance EN-88

MIDI Recorder and Audio Recorder Features	EN-88
Recording Features	EN-88
Playback Features	EN-90
Recording a Performance with the MIDI Recorder	EN-91
Main Content Recorded by the MIDI Recorder	EN-91
Preparing to Use the MIDI Recorder	EN-91
Recording	EN-92
Erasing the Recording of a Track	EN-95
Recording a Performance with the Audio Recorder	EN-96
Preparing to Use the Audio Recorder	EN-96
Recording an Audio Recorder Song (WAV)	EN-97
Recording to the Audio Recorder while Playing Back Data Recorded to the MIDI Recorder	EN-99
Deleting Audio Files from a USB Flash Drive	EN-102
Erasing the Last Audio File Numbered in the Internal Memory	EN-103
Erasing All Audio Files in the Internal Memory	EN-103

Listening back to a Performance Immediately (Instant RePlayer)	EN-104
Instant RePlayer	EN-104
Instant RePlayer Features	EN-104
Preparing to Use the Instant RePlayer	EN-104
Simple Usage	EN-105
Listen Back Using Marks	EN-106
What is a Mark?	EN-106
Performing	EN-106
Adding Marks at Desired Points within Performances	EN-106
Replaying from a Mark	EN-106
Listen Back Using Specified Number of Seconds	EN-108
Using a USB Flash Drive	EN-110
Using a Commercially Available USB Flash Drive – What You Can Do	EN-110
Preparing a USB Flash Drive	EN-111
Supported USB Flash Drives	EN-111
Types of Data that Can be Handled by this Digital Piano	EN-112
Inserting/Removing a USB Flash Drive from the Digital Piano	EN-114
Formatting a USB Flash Drive	EN-115
Operations with a USB Flash Drive	EN-117
Saving MIDI Recorder Songs to a USB Flash Drive	EN-117
Loading a MIDI File from a USB Flash Drive into the Digital Piano	EN-118
Deleting MIDI or Audio Files from a USB Flash Drive	EN-120
Save a Batch of Audio Files from the Internal Memory to a USB Flash Drive	EN-122
Loading Audio Files from a USB Flash Drive onto the Digital Piano in Batches	EN-123
Saving User Scenes to a USB Flash Drive	EN-124
Loading a User Scene File Saved on a USB Flash Drive onto this Digital Piano	EN-125
Delete user scene files on a USB flash drive	EN-126
Copying MIDI Song Data to a USB Flash Drive Using a Computer	EN-127
Copying Audio Data (WAV, MP3) to a USB Flash Drive Using a Computer	EN-127
Connecting Wirelessly	EN-128
Connecting the Digital Piano to External Devices Wirelessly	EN-128
Wireless (Bluetooth) Connectivity Settings	EN-128
Wireless Function On/Off	EN-128
Adjusting the Notification Tone Volume for Wireless Connection/Disconnection	EN-129
Bluetooth Low Energy MIDI Connectivity	EN-130
Bluetooth Audio Connectivity	EN-131
Bluetooth Audio Pairing	EN-131
Clearing Pairing Registration	EN-133
Adjusting Wireless Audio Playback Volume	EN-134
Using the Dedicated App	EN-135
Downloading the App (CASIO MUSIC SPACE) for Smart Devices	EN-135

Using with an External Device with a Cable Connection	EN-137
Connecting to a Computer or Smart Device and Using MIDI	EN-137
Computer Operating Environment.	EN-137
Connecting to a Computer	EN-138
Smart Device Operating Environment.	EN-139
Connecting a Smart Device with USB MIDI	EN-139
Outputting the Digital Piano's Sound to an Amplifier or Audio Equipment	EN-140
Connecting to Audio Equipment	EN-140
Connecting to a Musical Instrument Amplifier.	EN-141
Changing Settings	EN-142
Changing the Upper1 Part Settings	EN-142
Adjusting the Upper1 Part Volume	EN-142
Changing the Upper2 Part Settings	EN-143
Adjusting the Upper2 Part Volume	EN-143
Fine-Tuning the Upper2 Part (Upper2 Detune).	EN-143
Enabling/Disabling Upper2 Part Damper Pedal Effect	EN-144
Changing the Lower Part Settings	EN-145
Adjusting the Lower Part Volume	EN-145
Fine-Tuning the Lower Part (Lower Detune).	EN-145
Enabling/Disabling Lower Part Damper Pedal Effect	EN-146
Saving the Digital Piano Settings (Auto Resume).	EN-147
Restore Factory Defaults (Factory Reset).	EN-148
Adjusting Volume Balance	EN-149
Keyboard Volume	EN-149
MIDI Song Volume	EN-150
Audio Song Playback Volume	EN-150
Wireless Audio Playback Volume	EN-151
Center Cancel Function	EN-152
Changing MIDI Settings	EN-153
Local Control	EN-153
Keyboard Channel.	EN-153
Hi-Res Velocity MIDI OUT.	EN-154
Setting the Display of the Visual Information Bar	EN-155
Changing Display Settings	EN-155
Brightness Setting and No Lighting	EN-157

Main Digital Piano Settings	EN-158
Power On Alert	EN-158
Auto Power Off	EN-158
Touch Button Luminosity	EN-159
Left Panel Touch Button Sensitivity	EN-159
Front Panel Touch Button Sensitivity	EN-160
Panel Lock	EN-160
Switching Panel Light Settings	EN-161
Notification Tone Volume	EN-161
Notification Tone Set Selection	EN-162
Volume Sync Equalizer	EN-162
Speaker Out	EN-163
Headphone Mode	EN-164
Troubleshooting	EN-165
Error Display List	EN-167
Other Information	EN-171
Product Specifications	EN-171
Latest Support Information	EN-174
About the Contents of this Manual	EN-174
Trademarks and Registered Trademarks	EN-174
Operating Precautions	EN-175
Various Lists	EN-177
Tone List	EN-177
Demo Song List	EN-178
Music Library List	EN-179
Preset Scene List	EN-181
List of User Scene Record Items	EN-181
Keyboard Function List	EN-183
MIDI Implementation Chart	EN-190

Overview of the Digital Piano

Part Names and Functions

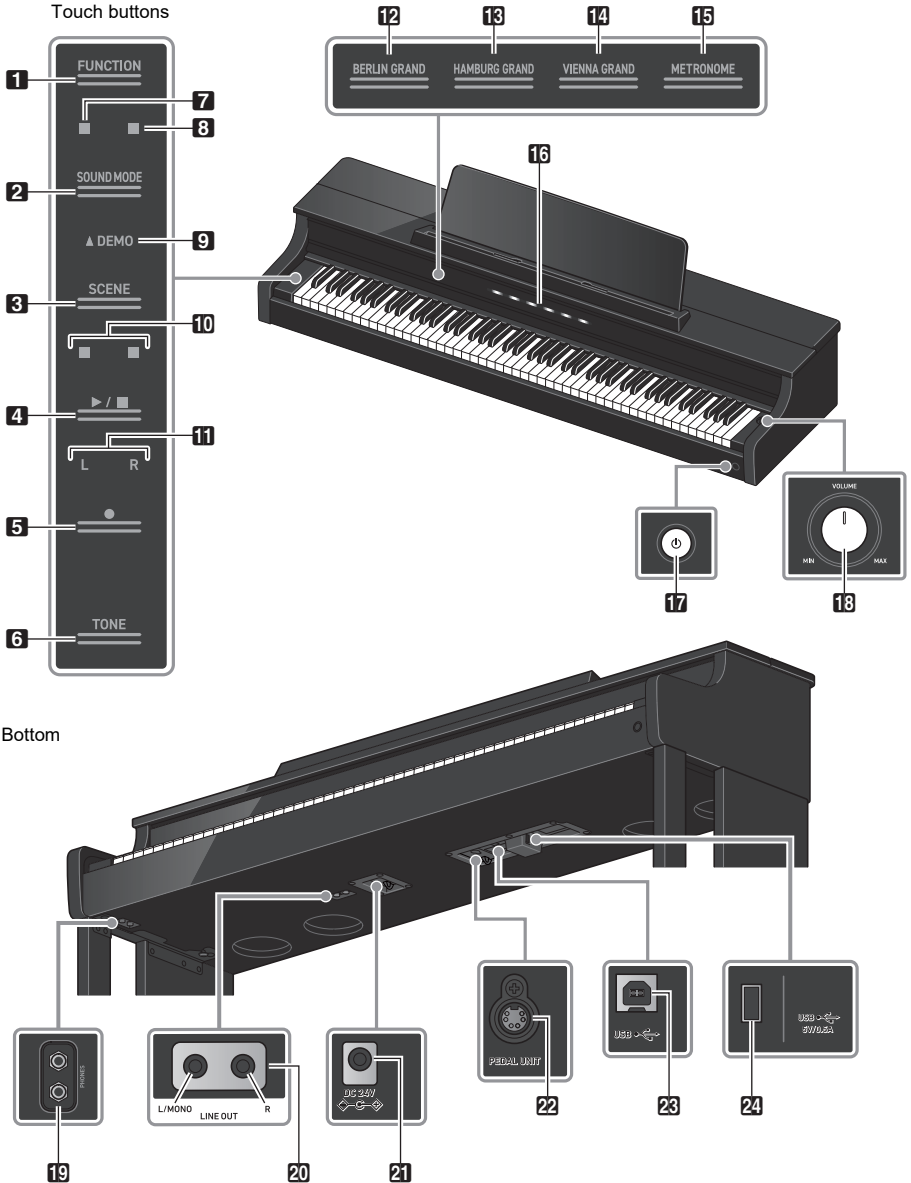

1 FUNCTION button

Used for basic settings.

2 SOUND MODE button

Used to change settings such as [SOUND MODE].

3 SCENE button

Use to change scene and metronome settings.

4 ►/■ button

Use to play/stop a song.

5 ●(REC) button

Use to record performances.

6 TONE button

Use to select tones and change tone settings.

7 Hall Simulator/Reverb Indicator

Lights up when [Hall Simulator/Reverb] is set to <On>.

8 Surround Indicator

Lights up when [Surround] is set to <On>.

9 DEMO Indicator

Lights up when a demo song is playing.

10 Beat Indicator

The left side blinks on the first beat and the right side blinks on the remaining beats in time, such as when a song is playing.

11 Track Indicator

During Record/Playback, “L” lights up to indicate the part of the track for the left hand, and “R” lights up to indicate the part of the track for the right hand.

12 BERLIN GRAND button

Sets the tone to <BERLIN GRAND>.

13 HAMBURG GRAND button

Sets the tone to <HAMBURG GRAND>.

14 VIENNA GRAND button

Sets the tone to <VIENNA GRAND>.

15 METRONOME button

Used to turn the metronome On/Off

16 Visual Information Bar

Notifies you of various pieces of information with a light.

17 ⏻(Power) button

Turns main power On/Off. The outer circumference of the button indicates Bluetooth® connection status by the color of the light.

18 Volume knob

Adjusts the volume of the Digital Piano.

- 19** PHONES jacks
- 20** LINE OUT R, L/MONO jacks
- 21** Power supply terminal (DC 24V)
- 22** PEDAL UNIT jack
- 23** USB Type B port
- 24** USB Type A port

Preparation Before Playing

Preparing a Power Supply

Use the AC adaptor (JEITA standard, with unified polarity plug) supplied with the Digital Piano. Use of other AC adaptors may cause smoke or malfunction.

Model of AC adaptor included with the Digital Piano: AD-E24250LW

Connect in the order of ① to ③ using the supplied power cord.

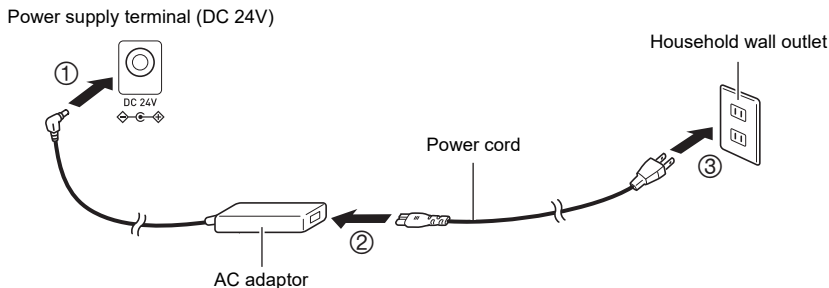

This AC adaptor cannot be repaired.

AC adaptor usage environment: Temperature 0 to 40°C, Humidity 10% to 90% RH

Output polarity:

IMPORTANT!

- Never connect the AC adaptor and power cord supplied with this Digital Piano to any other device. Doing so may cause malfunction.
- Be sure to turn the power off before unplugging and plugging in the AC adaptor.
- The AC adaptor will heat up slightly after prolonged use, this is not a malfunction.
- Unplug the AC adaptor from the power outlet when not using the Digital Piano for a long period of time.

Keyboard Cover

Be sure to open the keyboard cover completely before playing the Digital Piano.

IMPORTANT!

- When opening and closing the keyboard cover, be careful not to get the hands or fingers of yourself or others (especially children) caught in the keyboard cover.
- Do not let go of the keyboard cover with your hands or fingers when opening or closing it.
- Do not press down on the keyboard cover with your hand when closing it (your hand may get caught in the gap).
- Do not place any objects on the keyboard cover. There is a risk that objects may get inside the product when opening the keyboard cover.
- Do not play with the keyboard cover partially open.

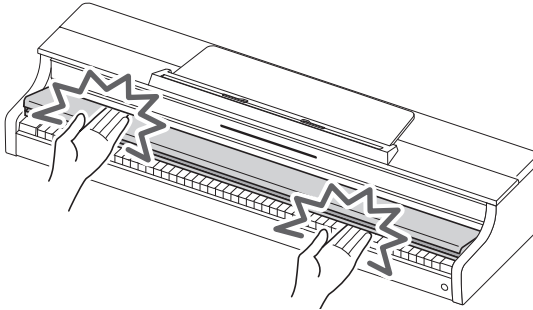

Opening the Keyboard Cover

Place both hands in the recess of the keyboard cover, lift it up slightly, and push it towards the back.

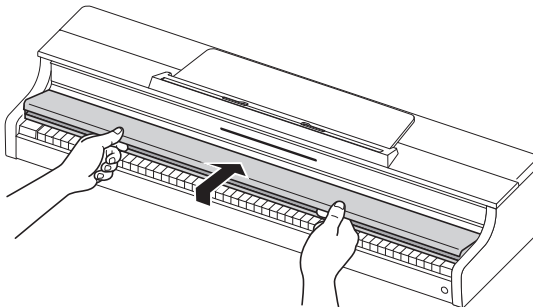

Closing the Keyboard Cover

Place both hands in the recess of the keyboard cover and slowly pull it toward you until it is completely closed.

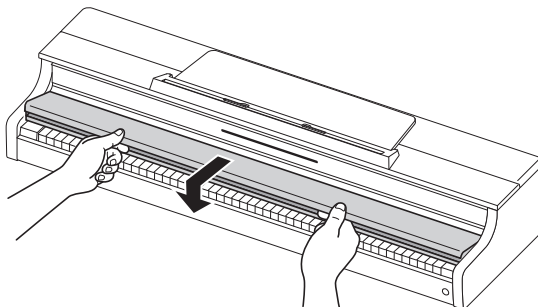

Turning the Power On/Off

Turning the Power On

1. Press the “⏻ (Power)” button to turn the Digital Piano on.



- When the power is turned on, each touch button will blink while the Digital Piano is starting up. When all touch buttons are lit up, the Digital Piano is ready for use.
- The power may not come on after pressing the “⏻ (Power)” lightly, however, this is not a malfunction. If this happens, firmly press the “⏻ (Power)” button again.
- A pop may be heard when turning the power on and off, but this is not a malfunction.
- If the Digital Piano is turned on without the Wireless MIDI & audio adaptor attached, the outer edge of the “⏻ (Power)” button will flash blue to indicate that the Wireless MIDI & audio adaptor is not attached.

2. Once the power is turned on, use the volume knob to adjust the volume.

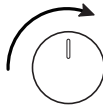

■ Auto Power Off Function

After approximately 20 minutes of inactivity, the power automatically turns off to prevent unnecessary power consumption. To prevent the power turning off between performances at concerts, etc., set the [Auto Power Off Function] to <Off>.

For more information, see “[Auto Power Off](#)”.

■ Power On Alert

After approximately 6 minutes without any operation, the touch buttons and Visual Information Bar will automatically switch to indicate that the power is still on. When an operation, such as touching a button or pressing a key, is performed, the Digital Piano will return to its normal state (all buttons lit up). You can switch the [Power On Alert] to operate or not.

For details, refer to “[Power On Alert](#)”.

Turning the Power Off

Press and hold the “ (Power)” button for about 2 seconds.



NOTE

- After the power is turned off using the “ (Power)” button, the Digital Piano will still be in standby mode, with a small current flowing through it. Always disconnect the AC adaptor from the power outlet when you do not intend to use the Digital Piano for an extended period of time, or when there is a risk of a lightning strike.

■ Saving Settings when the Power is Turned Off (Auto Resume)

When the Digital Piano is turned off, various settings such as tone numbers are reset. If [Auto Resume] is set to <On>, most settings will be saved even when the power is turned off.

For more information, see “[Saving the Digital Piano Settings \(Auto Resume\)](#)”.

Adjusting the Volume

The volume of the entire Digital Piano is controlled by the volume knob.



■ Automatically Correcting Sound Quality According to the Volume (Volume Sync Equalizer)

Automatically corrects the volume quality according to the volume output from the Digital Piano's speakers. You will be able to hear bass and treble clearly, even at low volumes.

For more information, see “[Volume Sync Equalizer](#)”.

■ Muting Sound from the Digital Piano's Speakers (Speaker Out)

If the [Speaker Out] setting is set to <Off>, no sound will be output from the speakers.

For more information, see “[Speaker Out](#)”.

Using the Supplied Wireless MIDI & Audio Adaptor

To connect the Digital Piano to an external device that supports Bluetooth® wireless technology, attach the Wireless MIDI & audio adaptor to the USB Type A port.

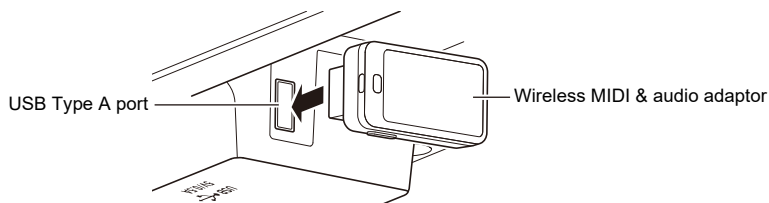

■ Connecting to Bluetooth Audio-Enabled Devices

By making a Bluetooth audio connection between this Digital Piano and a smart device, you can play sound from the smart device on this Digital Piano.

For more information, see “[Bluetooth Audio Connectivity](#)”.

■ Connecting to Bluetooth Low Energy MIDI-enabled Devices

Bluetooth Low Energy MIDI connection* between this Digital Piano and a smart device enables you to perform various operations using a dedicated app.

* Operation is not guaranteed if used with apps other than CASIO’s dedicated app.

For more information, see “[Bluetooth Low Energy MIDI Connectivity](#)”.

■ Using the Dedicated App (CASIO MUSIC SPACE)

Connect your smart device to the Digital Piano and use CASIO’s dedicated app.

For more information, see “[Using the Dedicated App](#)”.

IMPORTANT!

- When removing the Wireless MIDI & audio adaptor, turn the Digital Piano’s power off.

Using Headphones

Headphones allow you to enjoy playing at night without worrying about your surroundings. Turn down the volume on the Digital Piano before connecting headphones.

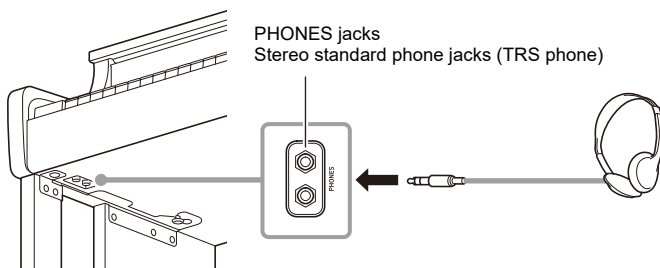

! IMPORTANT!

- Do not use headphones for long periods of time at high volume. This may result in hearing impairment.
- If the headphone plug does not match the terminal, use a commercially available conversion plug.
- When unplugging the headphone cord from the Digital Piano, be careful not to leave the conversion plug in the Digital Piano. If the plug is left in place, no sound may be produced when playing.
- Use headphones (commercially available) that meet the following standards:
Maximum input: 150 MW or more
Impedance: 32 Ω or more

■ Headphone Mode

When using headphones, this reproduces the natural sound that reaches your ears when you play an acoustic piano.

For more information, see "[Headphone Mode](#)".

■ Sound from Speakers While Headphones are Connected

When the [Speaker Out] setting is set to <On>, sound will come out of the speakers even if a plug is inserted into the PHONES jacks.

For more information, see "[Speaker Out](#)".

Using the Music Stand

Pull the music stand toward you and secure it with the hardware on the back.

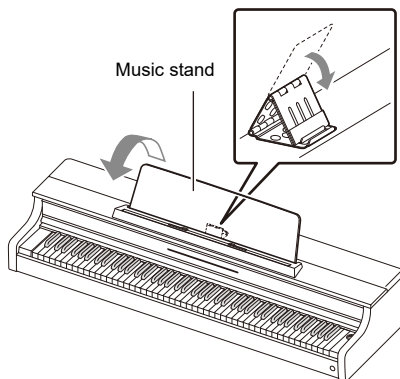

The Top Panel of the Digital Piano

IMPORTANT!

- Always open and close the top panel with both hands and be careful not to catch your fingers.
- Do not force the top panel to open further backward. This may cause damage.
- Stand to the right of the Digital Piano to open and close the top panel.

Opening the Top Panel of the Digital Piano

1. Lift the top panel.



2. Check that the metal fittings that support the top panel are upright inside the top panel.

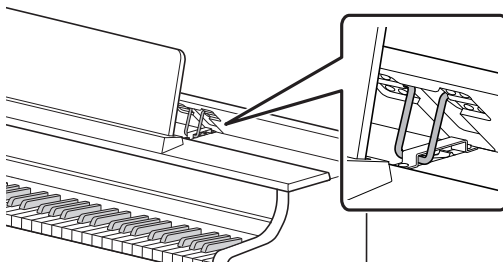

Closing the Top Panel of the Digital Piano

1. Lift the top panel gently upward.

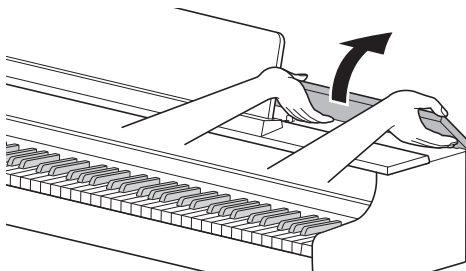

2. Slowly lower the top panel while pushing the metal fittings supporting the top panel backward with your fingers.



- To prevent the top panel from closing too vigorously, the metal fittings may temporarily stop in the middle area. When this happens, once again slowly lower the top panel while pushing the metal fittings backward with your fingers.

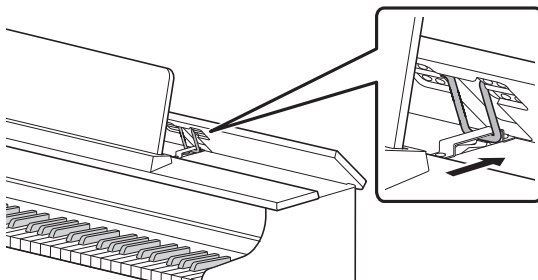

Read This First (Basic Operations and Settings)

Notation in this Manual

■ Notation of Function Names and their Setting Options

This manual describes how to make settings for the various functions. To make it easier to distinguish between the names of functions and the setting options for those functions, the names of functions are enclosed in [], and the setting options for those functions are enclosed in < >.

Example:

Switch the [RePlayer/Recorder] setting to <Instant RePlayer>.

- RePlayer/Recorder: Function Name
- Instant RePlayer: One of the options of the RePlayer/Recorder function

■ Notation of Note Names and Pitches on the Keyboard

Note names and pitches on the keyboard are indicated by the international representation (Middle C = "C4"), with the lowest C key named "C1" and the highest C key named "C8".

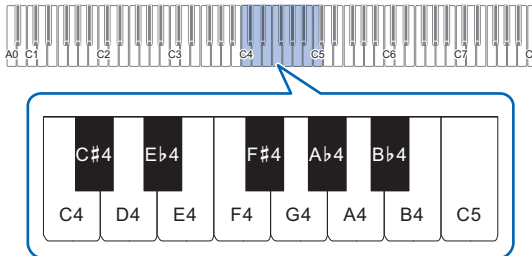

Touch Button Operation

When the Digital Piano is turned on, the touch buttons on the panel (left and front) light up. After no operation is performed for 15 seconds, the lights on the panel go off. When the lights are off, the touch buttons will light up again if you touch the panel.

You can change the number of seconds before the lights go off on the panel or set up the lights not to go off.

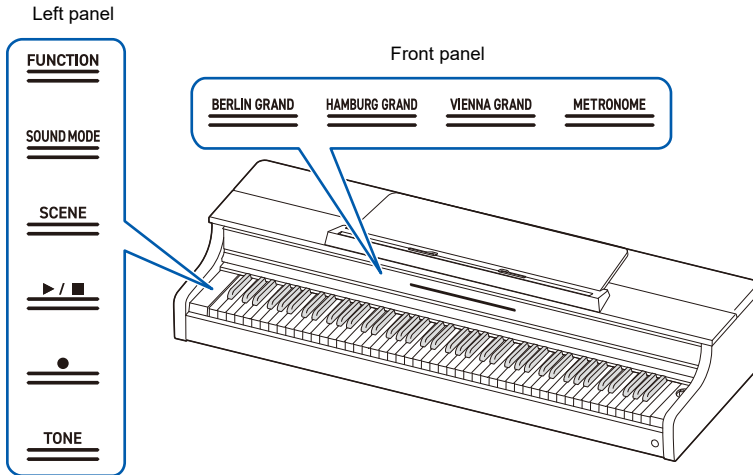

For more information, see “[Switching Panel Light Settings](#)”.



IMPORTANT!

- When operating the touch buttons, touch them firmly with bare fingers. There is no response to gloved fingers.
- Only the touch buttons that are active at the time will light up.

■ When Touch Buttons Do Not Respond

1. Turn off the power to the Digital Piano.
2. While pressing the C8 key (the rightmost key), press the “ (Power)” button.
 - Do not release the C8 key until the Digital Piano is turned on and the touch buttons start to blink. You can release the “ (Power)” button.
 - The sensitivity of the touch buttons is set to high.

Operation of the Touch Buttons Alone

Touching a button (touching firmly with a fingertip and releasing immediately) will execute the function of that button.

■ Left panel

Button	Function
SOUND MODE	Switches between <On> and <Off> for [Hall Simulator/Reverb] and [Surround].
SCENE	Recalls the settings for [SCENE] (default setting is <Preset Scene 1>).
▶/■	Plays/Stops songs and recordings.
●(REC)	Use to record performances.
TONE	The last tone selected using the keyboard (BERLIN GRAND by default) is selected.

- The “FUNCTION” button only executes a function when used in combination with the keyboard or with the “SOUND MODE” button. The “FUNCTION” button on its own does not execute any function.

■ Front panel

Button	Function
BERLIN GRAND	Selects <BERLIN GRAND> tone.
HAMBURG GRAND	Selects <HAMBURG GRAND> tone.
VIENNA GRAND	Selects <VIENNA GRAND> tone.
METRONOME	The metronome starts (or stops).

Touch Button and Keyboard Combination Operation

By using the touch buttons (except for the “●(REC)” button and the buttons on the front panel) and the keyboard at the same time, you can change various settings.

- The items to be set vary depending on the touch button pressed.
- The type of keyboard operation differs depending on the item you are setting.
- The Visual Information Bar blinks according to the setting value.
- There are five operation types as set out below:

■ Selecting a Setting Value Directly (operation type A)

- Select the setting value assigned to the key.

Example: Selecting a tone

While holding down the “TONE” button, press one of the C#3 to E \flat 6 keys (Tone Selection).

- See “Tone List” for the tones available for each key.

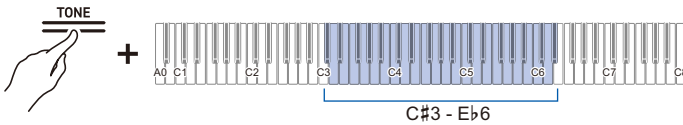

- The Visual Information Bar will blink at the approximate position of the selected value.



■ Using the +/- Keys to Raise or Lower the Setting Value by 1 (operation type B)

- Holding down a key changes the setting value continuously in increments.
- Pressing two keys together will return the value to the initial setting (default value).

Example: Setting the tempo

While holding down the “SCENE” button, press the B2 key (tempo –)/ C3 key (tempo +).

- This raises or lowers the tempo setting by 1.

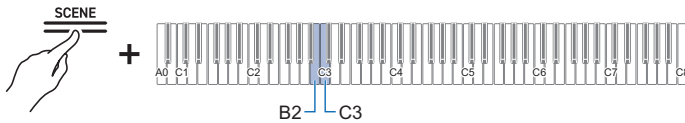

- The Visual Information Bar will blink at the approximate position of the selected value. (Leftmost: Minimum value, Rightmost: Maximum value)



■ Inputting Setting Values Using the Keys 0 to 9 (operation type C)

- For example, to enter the value “2”, press the B0 key (2). To enter the value “20”, press the B0 Key (2) and then the A0 Key (0).

Example: Setting the tempo

While holding down the “SCENE” button, press a key from A0 to F#1 (tempo setting).

- Sets the tempo in the range of 20 to 255 (beats per minute).

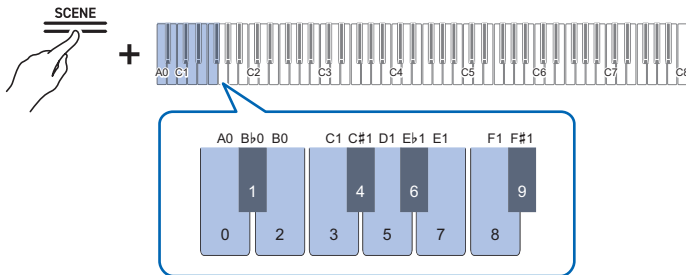

- The Visual Information Bar will blink at the approximate position of the selected value. (Leftmost: Minimum value, Rightmost: Maximum value)



■ Switching On/Off or Changing Setting Values Using a Single Key (operation type D)

- Each time the key is pressed, the setting is changed.
- When the key is pressed, a sound is played according to the set value.

Example: Locking button operations

While holding down the “FUNCTION” button, press the C8 key (Panel Lock).



- The Visual Information Bar blinks in the position of the selected value. (Left: Off, Middle: On, Right: Auto)



- For more information, see [“Panel Lock”](#).

■ Putting in Standby Mode, and Executing on Next Key Press (operation type E)

Example: Performing a Factory Reset

1. While holding down the “FUNCTION” button, press the A0 key (Factory Reset) to enter standby mode.

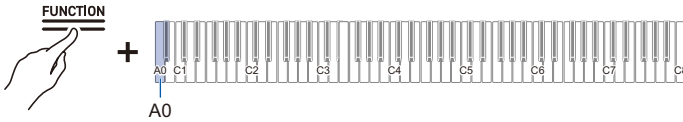

- To execute the process, do not release the touch button, and perform the operation in step 2.
- If the touch button is released in standby mode, the function will not be executed (the operation will be canceled).

2. Hold down the “FUNCTION” button and press the C1 key (Execute) to execute the process.

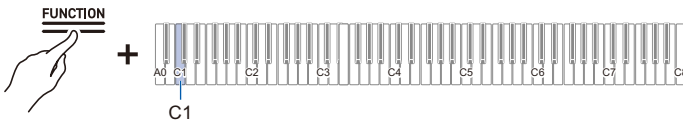

- After performing step 2, release the touch button.
- Processing may take some time. If so, wait until the process is complete.

NOTE

- When a touch button and keyboard keys are operated in combination, a notification tone sounds to inform the user of the result of the operation, and the Visual Information Bar displays.
- For details, see “[Notification Tones](#)” and “[How the Visual Information Bar Displays for Various Settings](#)”.

Notification Tones

When a touch button and keyboard keys are operated in combination, a notification tone sounds when the key is pressed to inform the user of the result of the operation.

Notification Tone Types

Notification Tone Type	Details of Notification
Tone for Accept	This is the sound made when a keyboard operation is accepted. Rings when the setting is turned on for setting items that toggle between on and off.
Tone for Invalid	This is the sound made when the wrong key is pressed. Keyboard operation is invalid when this tone sounds.
Tone for Upper and Lower Limits	This sound is made when the upper or lower limit of the set value is exceeded. Keyboard operation is invalid when this tone sounds.
Tone for Default Settings	This sound is made when the settings are returned to their default values. This sounds when the + and – keys are pressed at the same time, for example.
Tone for number notification	When one key is pressed continuously to toggle to a different setting value, the current setting value is indicated by the number of times the notification tone sounds.
Tone for Off	This is the sound made when the setting is switched off.
Separator Tone	This sound is made when the + or – key is used to increase or decrease a setting value and the number reaches a multiple of that value. For whole number-only settings a notification tone will sound each time the number is a multiple of 10. For a setting with a decimal value (e.g., 440.2), a notification tone sounds for whole numbers (e.g., 440 or 441).
Tone for Setting Completion	When multiple keys are pressed to set a value, this notification sound indicates that the setting is complete when the last key is pressed. For example, when entering a tempo setting value (3 digits), a notification tone sounds when the key for the third digit is pressed.







■ Changing Notification Tone Settings

You can choose one of three different notification tone sets and adjust the volume of the notification tones.

For more information, see [“Notification Tone Set Selection”](#) and [“Notification Tone Volume”](#).

How the Visual Information Bar Displays for Various Settings

When a touch button is held down and one key is pressed in succession to switch to a different setting value, the Visual Information Bar blinks according to the current setting value. The blinking light indicating the setting value moves from the left side to the right.

Setting Value	Display Pattern
2 values	
3 values	
4 values	
5 values	
6 values	
More than 7 values	<p data-bbox="232 794 1023 868">The leftmost (min. value) and rightmost (max. value) indicators in the Visual Information Bar light up and the approximate position of the set value blinks. On the default value, the indicator blinks rapidly.</p> 

■ Lighting Example (when there are two options)

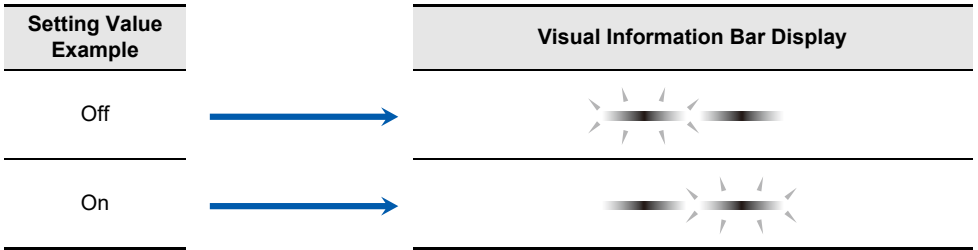

■ Lighting Example (when there are three options)

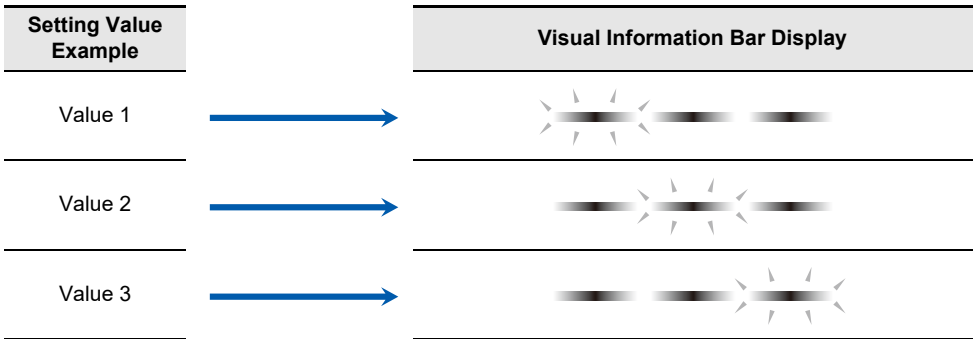

Piano Acoustic Setting and Demo Songs

Selecting the Acoustic Setting Appropriate for the Installation Location (Piano Position)

Optimize the acoustics according to the Digital Piano's position in the room.

While holding down the “SOUND MODE” button, press the E6 or F6 key.

[Selecting a Setting Value Directly \(operation type A\)](#)

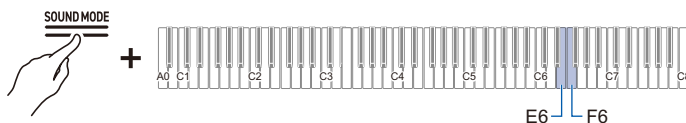

- Default value: Standard

Keyboard	Setting Value	Setting Details
E6	Standard	Standard settings
F6	Wall	Setup for installations close to the edge of a wall

Playing the Demo Songs

Hold down the “FUNCTION” button and press the “SOUND MODE” button.

- Playback of the demo songs (3 songs) will start. Refer to the “[Demo Song List](#)” for the song list.
- When the demo songs end, songs from the Music Library will play continuously from the fourth song onward. See “[Music Library List](#)” for song listings.

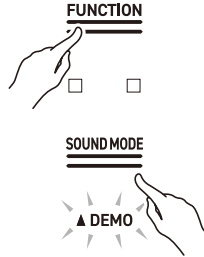

NOTE

- While the [Auto Power Off] setting is <On>, the power will turn off within a certain period of time after the entire demo performance.

Operations Possible during Demo Song Playback

You can change the song or [Sound Mode] Effects during demo song playback.

■ Skipping to Previous/Next Song

While holding down the “▶/■” button, press the B2 key (Song Select –)/C3 key (Song Select +).

[Using the +/- Keys to Raise or Lower the Setting Value by 1 \(operation type B\)](#)

■ Skip to Specific Song

While holding down the “▶/■” button, press one of the A0 to B0 keys (Demo songs) or one of the C#3 to C8 keys (Music Library Built-in Songs).

[Selecting a Setting Value Directly \(operation type A\)](#)

■ Changing the Sound Mode Effects

You can switch between <On> and <Off> for [Hall Simulator/Reverb] and [Surround].

[Using Sound Mode Effects \(Hall Simulator/Reverb and Surround\)](#)

Ending Demo Songs

Touch the “▶/■” button.

- Touch buttons that were unlit while the demo songs were playing will light again.



Playing

Selecting a Tone

The Digital Piano contains 28 tone types for all keys, including grand piano tones, 10 tone types from the Classical Piano Repertoire, and one bass tone scheme dedicated to the bass section.

- The tone names are marked on the upper side of the keyboard section of the Digital Piano (except for the Classical Piano Repertoire tones).

For more information, see [“Using the Keyboard to Select a Tone”](#).

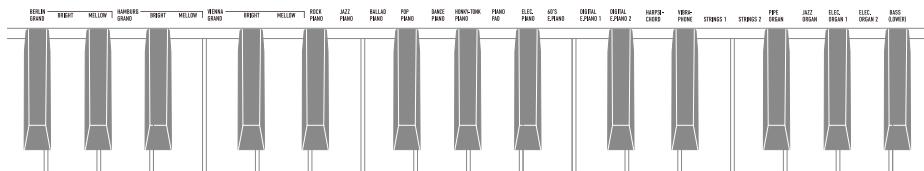

- In addition to selecting a single tone to play across the keyboard, two tones can be played on top of each other (Layer), and the bass tone can be assigned to the bass section.

For details, see [“Layering Two Tones \(Layer\)”](#) and [“Splitting Left and Right Keys \(Split\)”](#).

■ Grand Piano Tone Features

This Digital Piano has three types of grand piano tones: BERLIN GRAND, HAMBURG GRAND, and VIENNA GRAND. The grand piano tones each have different characteristics, so we recommend you choose the one that best suits the music you play and your preferences.

NOTE

- Three grand piano tones can be selected with a single touch of a button on the front panel. You can also select a tone using the [“Using the Keyboard to Select a Tone”](#).
- Each grand piano tone has two variations: BRIGHT and MELLOW (see table below). These variations of tones can be selected by pressing [“Using the Keyboard to Select a Tone”](#).

Tone Name	Characteristic
BERLIN GRAND	The sound has a clear outline, and is calm, elegant and light. The transparent sound and resonance create a beautiful melody rich in color. Suitable for playing impressionistic music.
BRIGHT	A bright and clear BERLIN GRAND tone.
MELLOW	A warm and calm BERLIN GRAND tone.
HAMBURG GRAND	This is strong and powerful with a wide range of dynamic expression; an elegant and polished sound beloved by many pianists. It can be used for all kinds of performances.
BRIGHT	A bright and clear HAMBURG GRAND tone.
MELLOW	A warm and calm HAMBURG GRAND tone.
VIENNA GRAND	This tone has an understated sound with rich expressiveness, powerful low frequency strings and a soft and delicate sound when notes are played gently. It is suitable for playing classical music.
BRIGHT	A bright and clear VIENNA GRAND tone.
MELLOW	A warm and calm VIENNA GRAND tone.

■ Classical Piano Repertoire Tone Features

Tone Name	Characteristic
SONATA GRAND	The sound changes throughout the dynamic range from softly played notes to strongly played notes. Suitable for playing dramatic music such as piano sonatas.
CONCERT ETUDE GRAND	The sound is shimmering and clear. Suitable for playing music that must be clearly audible to others, such as that played at a concert.
ETUDE GRAND	The sound quality is stable, granular and easy to hear, and has a solid dynamic range. This piano tone is ideal for everyday practice.
PRELUDE GRAND	The sound is soft, sparkling and full of character. Suitable for playing freestyle pieces such as preludes.
ROMANCE GRAND	The sound is soft and delicate with contours that accentuate the melody. Suitable for playing lyrical, instrumental works.
PARTITA GRAND	The sound is granular and has a light touch with moderate resonance. Suitable for playing pieces such as music for keyboard instruments from the Baroque period.
NOCTURNE GRAND	It has a beautiful melodious expression with a soft sound. Suitable for playing subdued and beautiful melodies reminiscent of the night, such as nocturnes.
WALTZ GRAND	The sound is bright and light, flamboyant and graceful. Suitable for playing fun and graceful dances like waltzes.
POLONAISE GRAND	The sound is imposing and powerful, with rhythmic patterns and resonant, full chords. Suitable for playing solemn and heroic music such as polonaises.
LITTLE PIECE UPRIGHT	It is the sound of an upright piano with a rustic, nostalgic feeling. Suitable for playing little pieces reminiscent of childhood.

Selecting a Single Tone

■ Using the Keyboard to Select a Tone

While holding down the “TONE” button, press one of the C#3 to E \flat 6 keys.

Selecting a Setting Value Directly (operation type A)

- See “Tone List” for the tones available for each key.

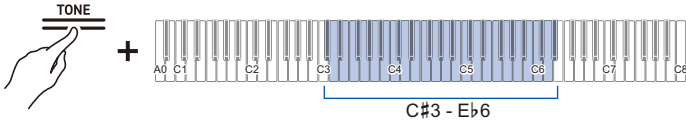

NOTE

- Instead of pressing the C#3 key (BERLIN GRAND) while holding down the “TONE” button, touch the “BERLIN GRAND” button to select BERLIN GRAND. Thus, the grand piano tone (BERLIN GRAND, HAMBURG GRAND, and VIENNA GRAND) can be selected with a single touch using the buttons on the front panel. Refer to “Using the Touch Button to Select a Tone” for more information.

Selecting Tones in the Order of the Tone List

While holding down the “TONE” button, press the B2 or C3 key.

Using the +/- Keys to Raise or Lower the Setting Value by 1 (operation type B)

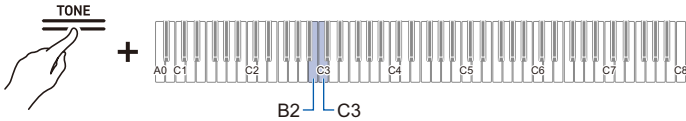

Keyboard	Setting
B2	Selects the previous tone (-)
C3	Selects the next tone (+)

■ Using the Touch Button to Select a Tone

Touch the “BERLIN GRAND” button, the “HAMBURG GRAND” button, or the “VIENNA GRAND” button.

- The grand piano tone corresponding to the button pressed is selected.



Touch the “TONE” button.

- The last tone selected using the keyboard (BERLIN GRAND by default) is selected.



NOTE

- Touching the “BERLIN GRAND” button, the “HAMBURG GRAND” button, or the “VIENNA GRAND” button will select the top tone (non-variation tone) of the grand piano tone corresponding to the button name. If you want to select a variation of a tone, follow the instructions under “[Using the Keyboard to Select a Tone](#)”. For more information about grand piano tones, see “[Grand Piano Tone Features](#)”.
- When [Layer] is <On>, touching the “BERLIN GRAND” button, “HAMBURG GRAND” button, “VIENNA GRAND” button, or “TONE” button will turn [Layer] <Off>.

Layering Two Tones (Layer)

You can have two tones sounding simultaneously when playing the keyboard. Since the tones are layered over each other, this feature is called Layer. The first tone selected is called the Upper1 part tone and the second tone selected is called the Upper2 part tone. When [Layer] is set to <On>, Upper1 and Upper2 parts will both sound at the same time.

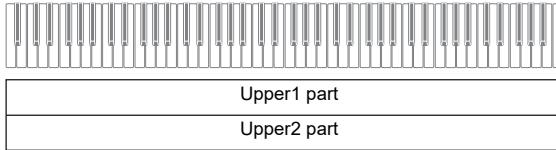

■ Turning Layer On/Off

While holding down the “TONE” button, press the C7 key (Layer).

Switching On/Off or Changing Setting Values Using a Single Key (operation type D)



- Default value: Off

Setting Value	Setting Details
Off	Turns Layer off.
On	Turns Layer on.

NOTE

- You can also touch one of the “BERLIN GRAND”, “HAMBURG GRAND”, “VIENNA GRAND”, or “TONE” buttons to turn [Layer] <Off>.

■ Selecting the Upper2 Part Tone

You can select the Upper2 part tone when [Layer] is set to <On>.

1. Turn [Layer] <On>.
2. While holding down the “TONE” button, press one of the C#3 to E5 or F#5 to E♭6 keys to select the tone for the Upper2 part.

[Selecting a Setting Value Directly \(operation type A\)](#)

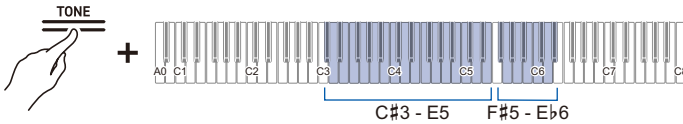

NOTE

- Upper1 Part tones can be selected when [Layer] is <OFF>.

■ Changing the Upper1 Part Settings

You can adjust the volume and perform Upper1 octave shift.

For details, see [“Changing the Upper1 Part Settings”](#) and [“Shifting Upper1 Part by an Octave”](#).

■ Changing the Upper2 Part Settings

You can adjust the Upper2 part volume and perform octave shift.

For details, see [“Changing the Upper2 Part Settings”](#) and [“Shifting Upper2 Part by an Octave”](#).

Splitting Left and Right Keys (Split)

You can select a tone dedicated to the bass section <BASS (LOWER)> to play bass notes in the bass section of the keyboard. This usage is called Split, since the entire keyboard is split into left and right. The tone of the bass section is called Lower Tone Section, and the tone of the treble section is called Upper1 Tone Section.

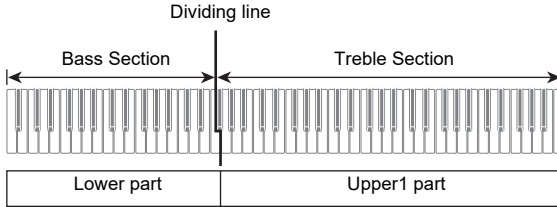

■ Selecting a Tone Exclusively for the Bass Section

While holding down the “TONE” button, press the F5 key (BASS).

Selecting a Setting Value Directly (operation type A)



- Only the bass section of the keyboard (left side) will have the BASS tone, while the treble section (right side) will remain the same as the previously selected tone.

■ Changing the Lower Part Settings

You can change the volume and other settings for the Lower Part.

For more information, see “[Changing the Lower Part Settings](#)”.

■ Changing the Upper1 Part Settings

You can adjust the volume and perform Upper1 octave shift.

For details, see “[Changing the Upper1 Part Settings](#)” and “[Shifting Upper1 Part by an Octave](#)”.

Splitting the Keyboard into Left and Right for Two-Person Performance (Duet)

What is a Duet?

You can have the same pitch range on the right and left sides from the center of the keyboard. This can be used when a teacher plays a model performance on the left side and the student plays the same melody on the right side. In addition, you can change the pitch range of the left and right keys by octaves.

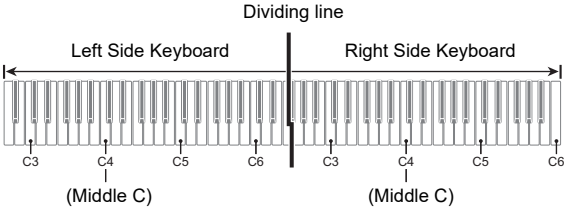

■ Pedal Operation for Duets (On/Pan)

The pedals at both ends are damper pedals for the left and right keys respectively, and the center pedal is a damper pedal for both the left and right keys.

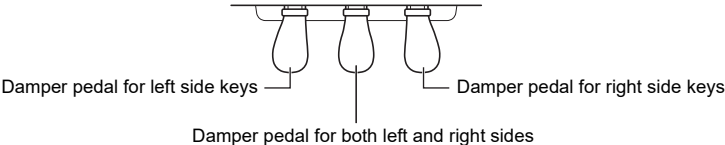

Using the Duet Function

While holding down the “FUNCTION” button, press the F2 key (Duet Mode).

Switching On/Off or Changing Setting Values Using a Single Key (operation type D)

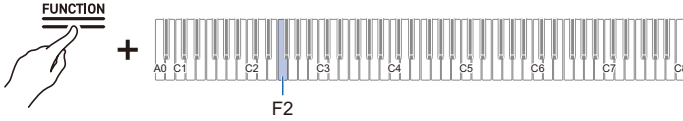

- Default value: Off

Setting Value	Notification Tone	Setting Details
Off	Tone for Off	Turns off Duet.
On	1 notification tone	Turns on Duet.
Pan	2 notification tones	The sound of the left keyboard is output from the left speaker only, and the sound of the right keyboard is output from the right speaker only.

NOTE

- Some settings cannot be changed while the [Duet] function is in use.
- When the [Duet] function is set to <Pan>, [Acoustic Simulator], [Hall Simulator/Reverb], [Surround] and [Chorus] are not available.

Changing the Pitch Range

For both the left and right keyboard, the range can be changed from -2 to +2 octaves.

While holding down the “FUNCTION” button, press the corresponding key.

Using the +/- Keys to Raise or Lower the Setting Value by 1 (operation type B)

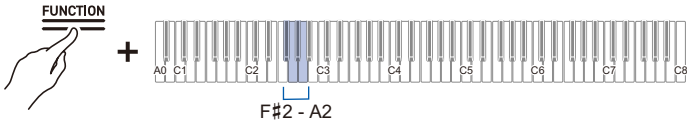

Left-Side Keyboard Settings

- Setting value: -2 octaves to +2 octaves
- Default value: 0

Keyboard	Setting
F#2	Lowers the range by one octave (-)
G2	Raises the range by one octave (+)
F#2 + G2	Resets the range to the default setting

Right Side Keyboard Setting

- Setting value: -2 octaves to +2 octaves
- Default value: 0

Keyboard	Setting
A \flat 2	Lowers the range by one octave (-)
A2	Raises the range by one octave (+)
A \flat 2 + A2	Resets the range to the default setting

Example of Setting Range

When the G2 key is pressed once

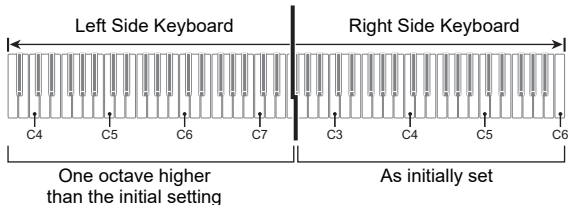

Using the Pedals

There are three pedals: Damper, Soft, and Sostenuto. You can enjoy expressive performances that feel closer to that of a grand piano using the pedals.

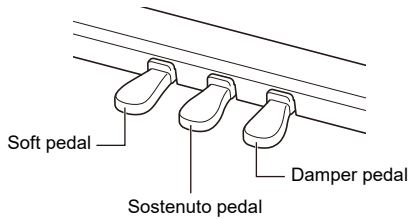

■ Damper Pedal

Pressing the damper pedal while playing will cause the notes you play to be sustained. When a grand piano tone is selected, you can also create a resonance effect (Damper Resonance) similar to when using a damper pedal on an acoustic grand piano. The effect of the pedal varies continuously with the depth at which it is pressed down.

■ Soft pedal

Pressing this pedal while playing suppresses notes played on the keyboard after the pedal was pressed, and makes them sound softer. The effect of the pedal varies continuously with the depth to which it is pressed down.

■ Sostenuto Pedal

Only the notes of the keys that are depressed when this pedal is pressed are sustained, even if the keyboard keys are released, until the pedal is released.

Adjusting the Position of Where the Half Pedal is Applied (Half Pedal Position)

While holding down the “FUNCTION” button, press the D6 or E♭6 keyboard key.

Using the +/- Keys to Raise or Lower the Setting Value by 1 (operation type B)

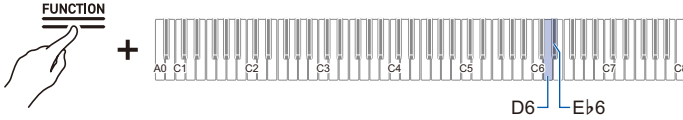

- Setting value: -2 (shallow) to 0 (standard) to +2 (deep)
- Default value: 0

Keyboard	Setting
D6	Makes the half pedal shallower by one step (-)
E♭6	Increases the half-pedal starting position by one step (+)
D6 + E♭6	Returns the half-pedal starting position to standard (0)

Using the Metronome

Metronome On/Off

The metronome beats at regular intervals. Using the metronome allows you to practice playing at a constant tempo. As soon as the metronome starts, the beat indicator and Visual Information Bar light up in time with the beat and tempo.

1. Touch the “METRONOME” button. The metronome will start.

- The beat indicator lights up in time with the metronome beat (left side for the first beat, right side for the remaining beats).



2. To stop the metronome, touch the “METRONOME” button again.

Setting the Beat

While holding down the “SCENE” button, press a key from C#3 to Bb3.

Selecting a Setting Value Directly (operation type A)

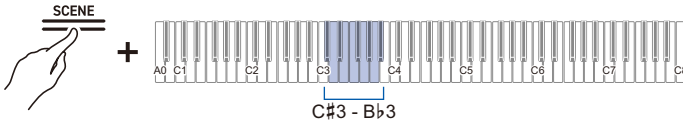

- Default value: 4

Keyboard	Setting Value	Setting Details
C#3	Off	Only a click sounds on each beat.
D3	1	A bell tone sounds on each beat.
Eb3	2	Sets the number of beats per bar to between 2 and 9. A bell tone sounds on the first beat, and a click sound is heard on each remaining beat.
E3	3	
F3	4	
F#3	5	
G3	6	
Ab3	7	
A3	8	
Bb3	9	

Setting a Tempo

■ Entering Tempo as a Number

Set the tempo for the metronome or song playback within the range of 20 to 255 (beats per minute). While holding down the “SCENE” button, use the A0 to F♭1 keys (Tempo setting) to enter the tempo setting value.

[Inputting Setting Values Using the Keys 0 to 9 \(operation type C\)](#)

■ Raising or Lowering the Tempo Value by 1

While holding down the “SCENE” button, press the B2 key (tempo -)/C3 key (tempo +).

[Using the +/- Keys to Raise or Lower the Setting Value by 1 \(operation type B\)](#)

■ Setting the Tempo from a Tempo Marking

Choose from a tempo marking such as Andante or Allegro.

While holding down the “SCENE” button, press one of the C2 to A♭2 keys (Tempo setting).

[Selecting a Setting Value Directly \(operation type A\)](#)

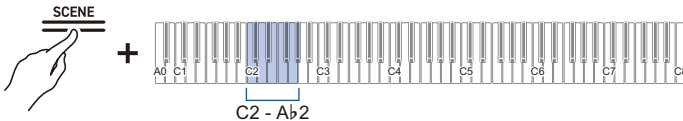

Keyboard	Setting Value	Tempo (beats per minute)
C2	Largo	46
C#2	Lento	52
D2	Adagio	56
E♭2	Andante	72
E2	Moderato	96
F2	Allegretto	108
F#2	Allegro	132
G2	Vivace	160
A♭2	Presto	184

■ Setting the Tempo Yourself by Tapping a Key (Tap Tempo)

While holding down the “SCENE” button, press the B♭2 key (Tap Tempo) two or more times in succession.

- The tempo will be set based on the interval between your key taps.

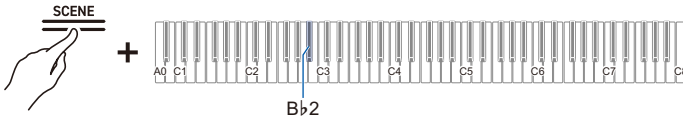

Adjusting the Volume

While holding down the “SCENE” button, press the A1 or B♭1 key.

Using the +/- Keys to Raise or Lower the Setting Value by 1 (operation type B)

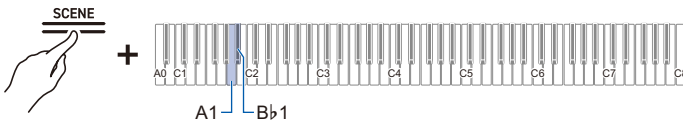

- Setting value: 0 (silence) to 42 (maximum volume)
A separator tone sounds when the set value becomes a multiple of 10.
- Default value: 25

Keyboard	Setting
A1	Decreases volume by 1 (-)
B♭1	Increases the volume by 1 (+)
A1 + B♭1	Resets volume to default setting

Applying Effects to Sound

Using Sound Mode Effects (Hall Simulator/Reverb and Surround)

Each time the “SOUND MODE” button is touched, effects are switched on and off in turn.

■ Hall Simulator/Reverb

This effect adds reverberation to the sound.

Hall Simulator

This effect simulates the different acoustic characteristics of world-famous concert halls and buildings.

Reverb

This reproduces the reverberation of a given space, such as a room or a hall.

■ Surround

Surround sound (spread effect) is applied to the output sound from the Digital Piano speakers.

Turning on/off Hall Simulator/Reverb and Surround

Touch the “SOUND MODE” button.

- Each time you touch the button, the indicators above the button will become lit or unlit as shown below.

<input type="checkbox"/> SOUND MODE	<input type="checkbox"/> SOUND MODE	<input type="checkbox"/> <input type="checkbox"/> SOUND MODE	<input type="checkbox"/> <input type="checkbox"/> SOUND MODE
Hall Simulator/Reverb <ON>	Hall Simulator/Reverb <OFF>	Hall Simulator/Reverb <ON>	Hall Simulator/Reverb <OFF>
Surround <OFF>	Surround <ON>	Surround <ON>	Surround <OFF>

Selecting Hall Simulator/Reverb Presets

While holding down the “SOUND MODE” button, press any one of the A0 to C#2 keys.

Selecting a Setting Value Directly (operation type A)

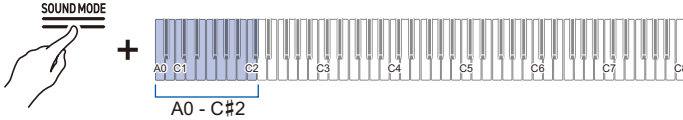

- Default value: Tone

Keyboard	Setting Value	Setting Details
A0	Tone	The type of hall simulator/reverb that best matches the current tone is automatically set.
Bb0	Salon	The various types of hall simulator. For example, “N.Y. Club” simulates the acoustics of a Manhattan music club, while “Berlin Hall” is an arena-style classical concert hall in Berlin.
B0	N.Y. Club	
C1	Scoring Stage	
C#1	Opera Hall	
D1	Viennese Hall	
Eb1	L.A. Hall	
E1	Berlin Hall	
F1	British Stadium	
F#1	Room 1	
G1	Room 2	
Ab1	Room 3	
A1	Large Room	
Bb1	Hall 1	Small hall-type reverb
B1	Hall 2	
C2	Hall 3	
C#2	Stadium	Stadium-type reverb

Adjusting Applied Hall Simulator/Reverb

While holding down the “**SOUND MODE**” button, press the corresponding key.

Using the +/- Keys to Raise or Lower the Setting Value by 1 (operation type B)

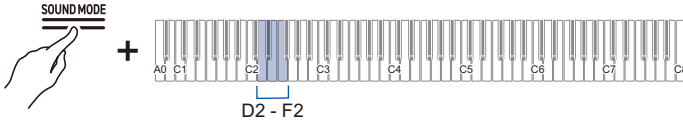

- Setting value: 0 (no effect) to 42 (maximum depth)
A separator tone sounds when the set value becomes a multiple of 10.

Keyboard	Setting
D2	Reduces the depth of effect applied to built-in sound sources by 1 (-)
E♭2	Increases the depth of effect applied to built-in sound sources by 1 (+)
D2+E♭2	Resets the depth of effect to the default setting for built-in sound sources (default value: 21)
E2	Decreases the depth of effect on the wireless audio input signal by 1 (-)
F2	Increases the depth of effect on the wireless audio input signal by 1 (+)
E2+F2	Resets the depth of effect to the default setting for the wireless audio input signal (default value: 0)

Selecting Surround Presets

While holding down the “**SOUND MODE**” button, press one of the **F#2 to Ab2** keys.

Selecting a Setting Value Directly (operation type A)

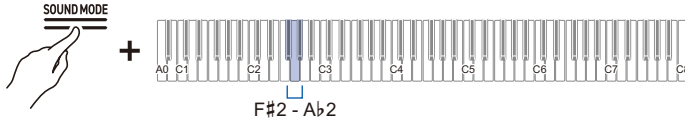

- Default value: Surround Type 2

Keyboard	Setting Value	Setting Details
F#2	Surround Type 1	Light effect
G2	Surround Type 2	Medium effect
Ab2	Surround Type 3	Heavy effect

Using Chorus

[Chorus] layers sounds to add depth.

While holding down the “SOUND MODE” button, press one of the C7 to C8 keys.

Selecting a Setting Value Directly (operation type A)

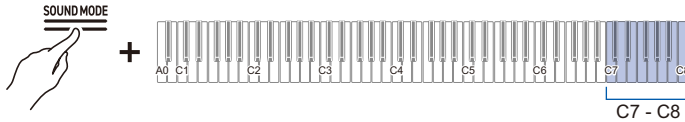

- Default value: Tone

Keyboard	Setting Value	Setting Details
C7	Tone	Automatically selects the chorus type appropriate for the current tone.
C#7	Chorus 1	Four chorus types with different sound depths.
D7	Chorus 2	
Eb7	Chorus 3	
E7	Chorus 4	
F7	Feedback Chorus	A chorus with feedback
F#7	Deep Chorus	This is the chorus with the deepest sound.
G7	Flanger 1	There are four types of flanger with different sound undulations and fluctuations.
Ab7	Flanger 2	
A7	Flanger 3	
Bb7	Flanger 4	
B7	Short Delay 1	A short delay. There are two types to choose from.
C8	Short Delay 2	

Adjusting Brilliance

[Brilliance] allows you to adjust the brightness of the sound.

While holding down the “SOUND MODE” button, press the B2 or C3 key.

Using the +/- Keys to Raise or Lower the Setting Value by 1 (operation type B)

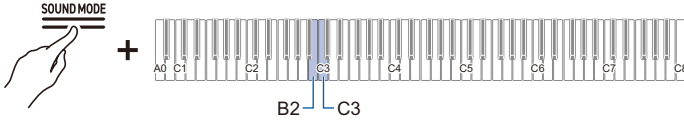

- Setting value: -12 to +12
- When set to +1 or higher, the sound is brighter, and when set to -1 or lower, the sound is mellower.
- Default value: 0

Keyboard	Setting
B2	Decreases the brilliance setting by 1 (-)
C3	Increases the brilliance setting by 1 (+)
B2+C3	Restores brilliance to default settings

Adjusting the Sound Characteristics of the Acoustic Piano Presets (Acoustic Simulator)

The piano tones of this Digital Piano have built-in elements that characterize the sound of an acoustic piano. Each of the tone characteristics can be adjusted.

Setting String Resonance

When playing acoustic piano, the strings, which are the overtones of the keys you play, resonate. Adjust the resonance by setting [String Resonance].

■ Setting [String Resonance] to <Tone> or <Off>

While holding down the “**SOUND MODE**” button, press the **C#3** or **D3** key.

Selecting a Setting Value Directly (operation type A)

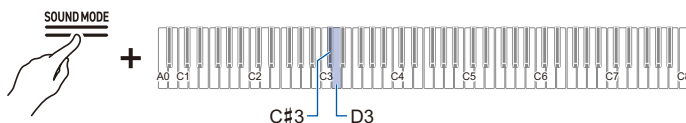

- Default value: Tone

Keyboard	Setting Value	Setting Details
C#3	Tone	Automatically sets a value appropriate for the current tone.
D3	Off	Disables String Resonance.

■ Adjusting the Resonance by Changing the Value of the [String Resonance] Setting

While holding down the “**SOUND MODE**” button, press the **E \flat 3** or **E3** key.

Using the +/- Keys to Raise or Lower the Setting Value by 1 (operation type B)

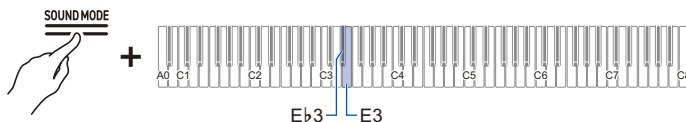

- Set value: Tone, Off, 1–10
The larger the number, the stronger the String Resonance effect.
- Default value: Tone

Keyboard	Setting Details
E \flat 3	Decreases the strength of the String Resonance by 1 (-)
E3	Increases the strength of the String Resonance by 1 (+)

Setting Damper Resonance

When pressing the damper pedal of an acoustic piano, the strings of all 88 keys are released, meaning all the strings that are harmonics of the played keys resonate. Adjust the degree of resonance by setting [Damper Resonance].

■ Setting [Damper Resonance] to <Tone> or <Off>

While holding down the “SOUND MODE” button, press the F3 or F#3 key.

Selecting a Setting Value Directly (operation type A)

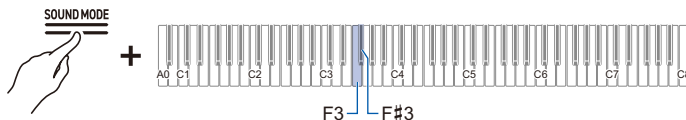

- Default value: Tone

Keyboard	Setting Value	Setting Details
F3	Tone	Automatically sets a value appropriate for the current tone.
F#3	Off	Disables Damper Resonance.

■ Adjusting the Resonance by Changing the Value of the [Damper Resonance] Setting

While holding down the “SOUND MODE” button, press the G3 or A♭3 key.

Using the +/- Keys to Raise or Lower the Setting Value by 1 (operation type B)

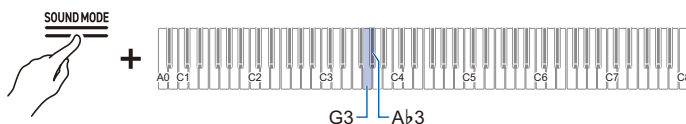

- Set value: Tone, Off, 1–10
The larger the number, the stronger the Damper Resonance effect.
- Default value: Tone

Keyboard	Setting Details
G3	Lowers the strength of the Damper Resonance by 1 (–)
A♭3	Increases the strength of the Damper Resonance by 1 (+)

Setting Damper Noise

When pressing the damper pedal on an acoustic piano, a small noise is produced when the damper moves away from the piano wire. Adjust the volume of the noise by setting [Damper Noise].

■ Setting [Damper Noise] to <Tone> or <Off>

While holding down the “SOUND MODE” button, press the **A3** or **B♭3** key.

Selecting a Setting Value Directly (operation type A)

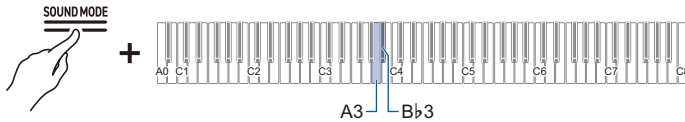

- Default value: Tone

Keyboard	Setting Value	Setting Details
A3	Tone	Automatically sets a value appropriate for the current tone.
B♭3	Off	Disables Damper Noise.

■ Adjusting the Noise Volume by Changing the Value of the [Damper Noise] Setting

While holding down the “SOUND MODE” button, press the **B3** or **C4** key.

Using the +/- Keys to Raise or Lower the Setting Value by 1 (operation type B)

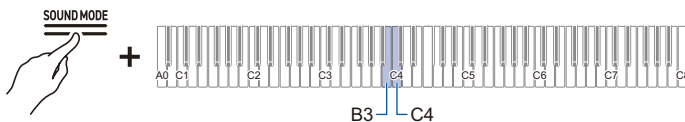

- Set value: Tone, Off, 1–10
The higher the setting value, the louder the Damper Noise.
- Default value: Tone

Keyboard	Setting Details
B3	Lowers the Damper Noise volume by 1 (–)
C4	Increases the Damper Noise volume by 1 (+)

Setting Open String Resonance

The high register of an acoustic piano has no damper and is always open string, which gives a unique resonance. Adjust the resonance by setting [Open String Resonance].

■ Setting [Open String Resonance] to <Tone> or <Off>

While holding down the “SOUND MODE” button, press the C#4 or D4 key.

Selecting a Setting Value Directly (operation type A)

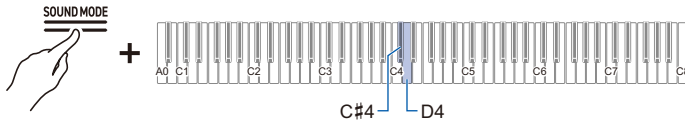

- Default value: Tone

Keyboard	Setting Value	Setting Details
C#4	Tone	Automatically sets a value appropriate for the current tone.
D4	Off	Disables Open String Resonance.

■ Adjusting the Resonance by Changing the Value of the [Open String Resonance] Setting

While holding down the “SOUND MODE” button, press the Eb4 or E4 key.

Using the +/- Keys to Raise or Lower the Setting Value by 1 (operation type B)

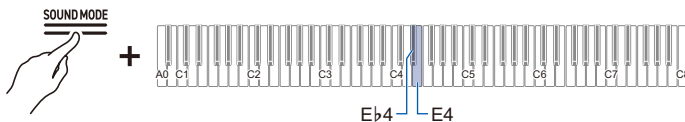

- Set value: Tone, Off, 1–10
- The larger the setting value, the stronger the resonance due to Open String Resonance.
- Default value: Tone

Keyboard	Setting Details
Eb4	Reduces the strength of the Open String Resonance by 1 (–)
E4	Increases the strength of the Open String Resonance by 1 (+)

Setting the Aliquot Resonance

An aliquot is a resonator that is sometimes used in acoustic pianos. It uses the resonance of additional strings in the middle and upper registers. It is sometimes referred to as the Duplex Scale. Adjust its resonance by setting [Aliquot Resonance].

■ Setting [Aliquot Resonance] to <Tone> or <Off>

While holding down the “SOUND MODE” button, press the F4 or F#4 key.

Selecting a Setting Value Directly (operation type A)

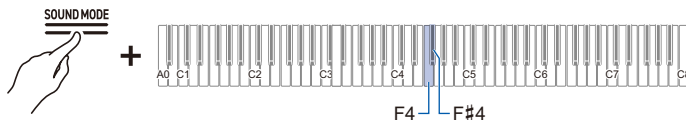

- Default value: Tone

Keyboard	Setting Value	Setting Details
F4	Tone	Automatically sets a value appropriate for the current tone.
F#4	Off	Disables Aliquot Resonance.

■ Adjusting the Resonance by Changing the Value of the [Aliquot Resonance] Setting

While holding down the “SOUND MODE” button, press the G4 or Ab4 key.

Using the +/- Keys to Raise or Lower the Setting Value by 1 (operation type B)

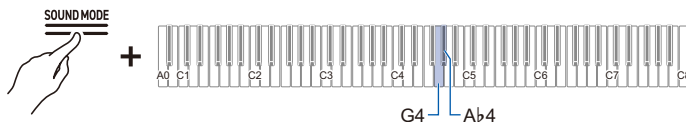

- Set value: Tone, Off, 1–10
- 1 to 10: The higher the value, the stronger the Aliquot Resonance.
- Default value: Tone

Keyboard	Setting Details
G4	Reduces the Aliquot Resonance strength by 1 (-)
Ab4	Increases the Aliquot Resonance strength by 1 (+)

Setting Pedal Action Noise

Using the pedals of an acoustic piano produces a mechanical sound (noise). Adjust the volume of this noise by setting [Pedal Action Noise].

■ Setting [Pedal Action Noise] to <Tone> or <Off>

While holding down the “SOUND MODE” button, press the **A4** or **B \flat 4** key.

Selecting a Setting Value Directly (operation type A)

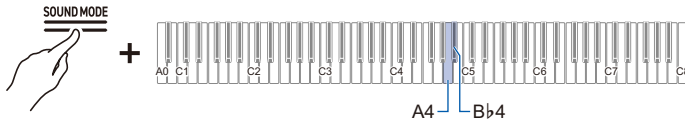

- Default value: Tone

Keyboard	Setting Value	Setting Details
A4	Tone	Automatically sets a value appropriate for the current tone.
B \flat 4	Off	No pedal action noise will be produced.

■ Adjusting the Noise Level by Changing the Value of the [Pedal Action Noise] Setting

While holding down the “SOUND MODE” button, press the **B4** or **C5** key.

Using the +/- Keys to Raise or Lower the Setting Value by 1 (operation type B)

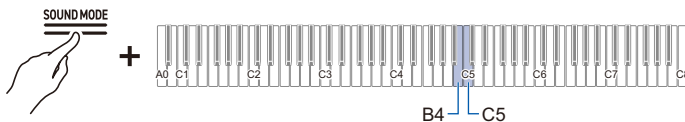

- Setting value: Tone, Off, 1–10
The higher the setting value, the louder the pedal action noise.
- Default value: Tone

Keyboard	Setting Details
B4	Reduces the Pedal Action Noise volume by 1 (–)
C5	Increases the Pedal Action Noise volume by 1 (+)

Setting Key On Action Noise

When playing the keys very softly on an acoustic piano, the hammers do not reach the strings and only the mechanical action (noise) of the piano is heard. Adjust the volume of the noise by setting [Key On Action Noise].

■ Setting [Key On Action Noise] to <Tone> or <Off>

While holding down the “**SOUND MODE**” button, press the **C#5** or **D5** key.

Selecting a Setting Value Directly (operation type A)

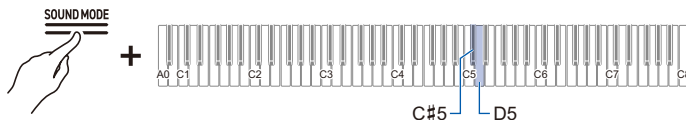

- Default value: Tone

Keyboard	Setting Value	Setting Details
C#5	Tone	Automatically sets a value appropriate for the current tone.
D5	Off	No Key On Action Noise made.

■ Adjusting the Noise Level by Changing the Value of the [Key On Action Noise] Setting

While holding down the “**SOUND MODE**” button, press the **E♭5** or **E5** key.

Using the +/- Keys to Raise or Lower the Setting Value by 1 (operation type B)

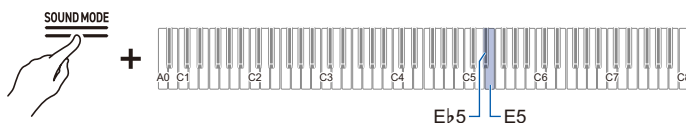

- Setting value: Tone, Off, 1–10
The higher the setting value, the louder the Key On Action Noise.
- Default value: Tone

Keyboard	Setting Details
E♭5	Decreases the Key On Action Noise volume by 1 (–)
E5	Increases the of Key On Action Noise volume by 1 (+)

Setting Key Off Action Noise

When a finger is removed from the keyboard of an acoustic piano, this generates a sound corresponding to the mechanical piano action (noise). Adjust the volume of the noise by setting [Key Off Action Noise].

■ Setting [Key Off Action Noise] to <Tone> or <Off>

While holding down the “**SOUND MODE**” button, press the **F5** or **F#5** key.

Selecting a Setting Value Directly (operation type A)

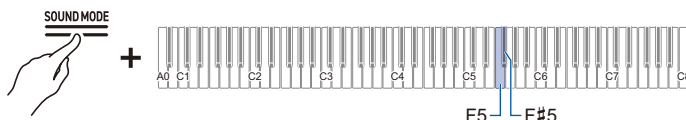

- Default value: Tone

Keyboard	Setting Value	Setting Details
F5	Tone	Automatically sets a value appropriate for the current tone.
F#5	Off	No Key Off Action Noise is made.

■ Adjusting the Noise Volume by Changing the Value of the [Key Off Action Noise] Setting

While holding down the “**SOUND MODE**” button, press the **G5** or **A♭5** key.

Using the +/- Keys to Raise or Lower the Setting Value by 1 (operation type B)

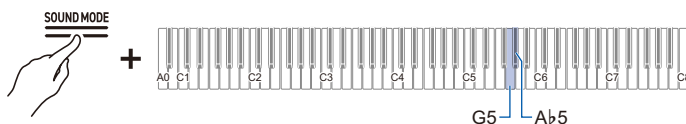

- Setting value: Tone, Off, 1–10
The higher the setting value, the louder the Key Off Action Noise.
- Default value: Tone

Keyboard	Setting Details
G5	Decreases the Key Off Action Noise volume by 1 (–)
A♭5	Increases the Key Off Action Noise volume by 1 (+)

Setting Lid Simulator

The sound of a grand piano changes depending on how open the lid is. With this Digital Piano, when you adjust the opening of the lid using the [Lid Simulator], the change in sound is simulated using digital processing. (The Lid Simulator is unrelated to the top panel opening/closing mechanism of the housing.)

While holding down the “SOUND MODE” button, press any one of the A5 to C#6 keys.

Selecting a Setting Value Directly (operation type A)

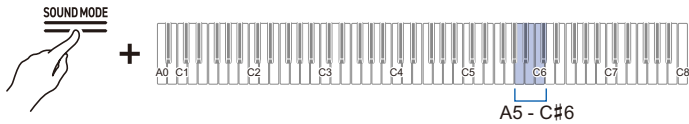

- Default value: Tone

Keyboard	Setting Value	Setting Details
A5	Tone	Automatically sets a value appropriate for the current tone.
B \flat 5	Close	The lid is closed.
B5	Semi	The lid is slightly open.
C6	Full	The lid is fully open.
C#6	Remove	The lid is removed.

Adjusting Key Touch

Changing the Volume Made by the Strength of Pressure Placed on a Key (Touch Response)

The [Touch Response] function changes the volume according to the strength (speed) with which a player presses a key. The [Touch Response] function enables the volume and sound quality to change according to the strength (speed) with which a player presses a key, just like an acoustic piano, enriching the expression of performances.



Press quickly to produce a loud sound.



Press slowly to produce a quiet sound.



Do not press too vigorously.

Changing the sensitivity of Touch Response

While holding down the “TONE” button, press one of the Eb1 to Ab1 keys.

Selecting a Setting Value Directly (operation type A)

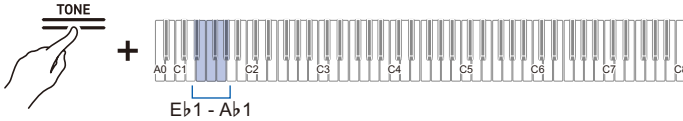

- Default value: 3

Keyboard	Setting Value	Setting Details
Eb1	Off	Cancels Touch Response. The volume remains constant even when key pressing speed changes.
E1	1 (Light)	This setting makes it easier to produce loud sounds, and the touch feels lighter than “Normal”.
F1	2 (Medium light)	
F#1	3 (Normal)	Standard setting.
G1	4 (Medium heavy)	This setting makes it difficult to produce loud sounds, and the touch feels heavier than “Normal”.
Ab1	5 (Heavy)	

Adjusting the Timing of Key Press to Sound (Hammer Response)

On an acoustic piano, the size of the hammer that strikes the strings is different for each key range, so the timing of sound production differs depending on the key range. Adjusts the timing between when a key is pressed and when a note sounds.

Adjusting Hammer Response

■ Set [Hammer Response] to <Tone> or <Off>.

While holding down the “TONE” button, press the A1 or B♭1 key.

Selecting a Setting Value Directly (operation type A)

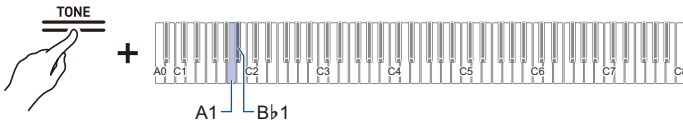

• Default value: Tone

Keyboard	Setting Value	Setting Details
A1	Tone	The optimum value for the current tone is set.
B♭1	Off	The fastest response is set for all keys.

- Change the value of the [Hammer Response] setting to adjust the timing from when the key is pressed to when the note is sounded.

While holding down the “TONE” button, press the B1 or C2 key.

Using the +/- Keys to Raise or Lower the Setting Value by 1 (operation type B)

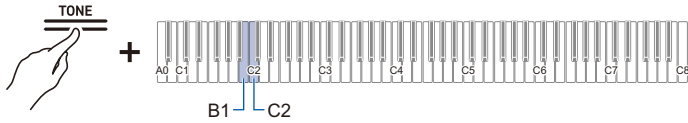

- Setting value: Tone, Off, 1–10
The smaller the setting value, the faster the timing between keyboard press and note sounding, and the larger the value, the slower.
- Default value: Tone

Keyboard	Setting Details
B1	Speeds up the timing between pressing the keyboard key and the note sounding by one step (-)
C2	Delays the timing between keyboard press and note sound by one step (+)

Adjusting the Timing of Mute During Key Release (Key Off Response)

On a grand piano, when you release a key, the damper comes down on the strings and the sound stops. The Key Off Response function digitally simulates the timing of when a note stops sounding based on movement during key release. This function allows the next note to be sounded without having to fully return to the key when hitting the same note in succession, as on a grand piano, and enables detailed touch expression, such as the way notes are connected and cut off, allowing the player to perform with a natural feel. Adjusts the timing from when the key is released until the sound mutes.

Adjusting Key Off Response

While holding down the “TONE” button, press one of the Eb2 to F#2 keys.

Selecting a Setting Value Directly (operation type A)

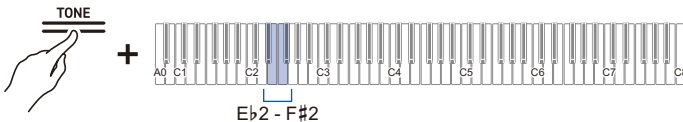

- Default value: Tone

Keyboard	Setting Value	Setting Details
Eb2	Tone	The optimum value for the current tone is set.
E2	Fast	The timing until the note mutes after releasing a key is faster.
F2	Normal	Standard setting.
F#2	Slow	The timing until the note mutes after releasing a key is later.

Adjusting the Pitch of Sound

Changing the Pitch in Semitone Steps (Transpose)

Raise or lower the overall pitch of all notes in semitone steps. This is useful when you want to play a difficult key in a familiar key, or when you want to raise or lower the key of the accompaniment to match the pitch of a singer's voice.

Transpose

While holding down the “**TONE**” button, press the **C#1** or **D1** key.

Using the +/- Keys to Raise or Lower the Setting Value by 1 (operation type B)

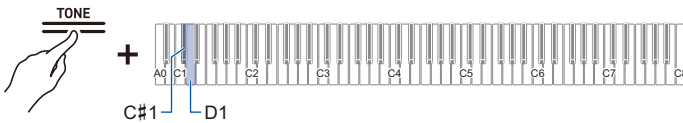

- Setting value: -12 to +12 semitones
- Default value: 0

Keyboard	Setting
C#1	Lowers the pitch of all notes by a semitone (-)
D1	Raises the pitch of all notes by a semitone (+)
C#1 + D1	Resets the pitch of all notes to default setting

Fine-tuning (A-tuning)

Shift the overall pitch of the Digital Piano slightly. Set the frequency of the A4 note in the range of 415.5 to 465.9 Hz (default 440.0 Hz).

Tuning

■ Select 440.0 Hz or 442.0 Hz

While holding down the “FUNCTION” button, press the A4 or B \flat 4 key.

Selecting a Setting Value Directly (operation type A)

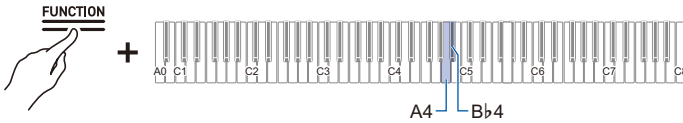

- Default value: 440.0 Hz

Keyboard	Setting
A4	Sets the frequency of the A4 note to 440.0 Hz
B \flat 4	Sets the frequency of the A4 note to 442.0 Hz

■ Changing in 0.1 Hz Increments

While holding down the “FUNCTION” button, press the B4 or C5 key.

Using the +/- Keys to Raise or Lower the Setting Value by 1 (operation type B)

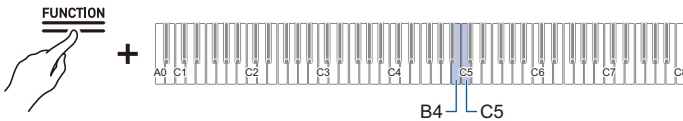

- Set value: 415.5 to 465.9 Hz
A separator tone sounds when the frequency reaches a whole number (such as 440 or 441).
- Default value: 440.0 Hz

Keyboard	Setting
B4	Decreases the frequency of the A4 note by 0.1 Hz (-)
C5	Raises the frequency of the A4 note by 0.1 Hz (+)

Shifting by Octaves (Octave Shift)

The pitch of the sound can be raised or lowered in octaves.

Each part (Upper1, Upper2) can be set independently when using [Layer].

For more information about layers and their respective parts, see “[Layering Two Tones \(Layer\)](#)”.

Shifting Upper1 Part by an Octave

While holding down the “TONE” button, press the B0 or C1 key.

Using the +/- Keys to Raise or Lower the Setting Value by 1 (operation type B)

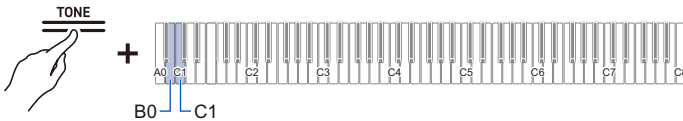

- Setting value: -2 to +2 octaves
- Default value: 0

Keyboard	Setting
B0	Lowers the pitch of the Upper1 part by one octave (-)
C1	Raises the pitch of the Upper1 part by one octave (+)
B0 + C1	Resets the Upper1 part pitch to the default setting

Shifting Upper2 Part by an Octave

While holding down the “TONE” button, press the E \flat 7 or E7 key.

Using the +/- Keys to Raise or Lower the Setting Value by 1 (operation type B)

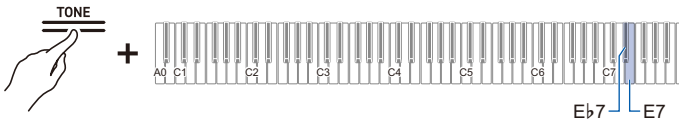

- Setting value: -2 to +2 octaves
- Default value: 0

Keyboard	Setting
E \flat 7	Lowers the pitch of the Upper2 part by one octave (-)
E7	Raises the pitch of the Upper2 part by one octave (+)
E \flat 7 + E7	Resets the Upper2 part pitch to the default setting

Changing the Scale Tuning (Temperament) of the Keyboard

By setting the scale of the keys, you can play music (Indian, Arabic, classical, etc.) that uses a scale other than the regular temperament (12 equal temperament). You can choose your favorite scale from 17 preset scales.

Changing the Scale Tuning

While holding down the “FUNCTION” button, press the F4 key (Scale Tuning Selection).

Switching On/Off or Changing Setting Values Using a Single Key (operation type D)

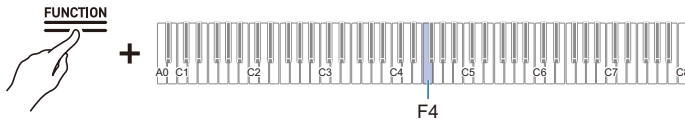

- A tone for default setting sounds when the set value reaches 0, and a separator tone sounds when the set value reaches 10.
- Default value: 0

Setting Value	Scale (Temperament)
0	Equal Temperament
1	Pure Major Temperament
2	Pure Minor Temperament
3	Pythagorean Temperament
4	Kirnberger 3 Temperament
5	Werckmeister Temperament
6	Mean-Tone Temperament
7	Rast
8	Bayati
9	Hijaz
10	Saba
11	Dashti
12	Chahargah
13	Segah
14	Gurjari Todi
15	Chandrakauns
16	Charukeshi

Setting the Scale Tuning Base Note

1. While holding down the “FUNCTION” button, press the F#4 key (Scale Tuning base note).

Putting in Standby Mode, and Executing on Next Key Press (operation type E)

- Do not release the “FUNCTION” button until the next operation is complete.

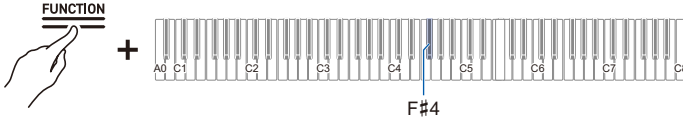

2. While holding down the “FUNCTION” button, specify the base note (C to B) you wish to set on the keyboard.

- Specify the base note by pressing one of the 88 keys.

Switching Stretch Tuning On/Off

Generally, on a piano, the high notes are tuned higher and the low notes are tuned lower. This tuning is called “Stretch Tuning”.

While holding down the “FUNCTION” button, press the G4 key (Stretch Tuning).

Switching On/Off or Changing Setting Values Using a Single Key (operation type D)

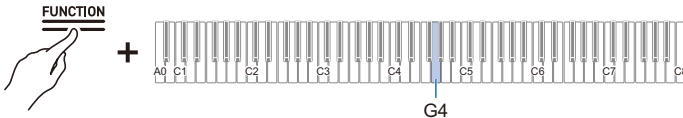

- Default value: On

Setting Value	Setting Details
Off	Turns off Stretch Tuning.
On	Turns on Stretch Tuning.

Selecting the Appropriate Setting for the Song or Scene to be Played (Scene)

Preset Scenes and User Scenes

The Digital Piano has 10 preset scenes with settings adjusted to suit the song or scene to be played. You can select a scene and instantly change the settings of the Digital Piano. You can also create your own favorite scenes (User Scenes) and store up to 10 of them in the memory.

Calling Up a Scene

While holding down the “SCENE” button, press one of the C5 to A5 keys (Preset Scene) or C4 to A4 keys (User Scene).

Selecting a Setting Value Directly (operation type A)

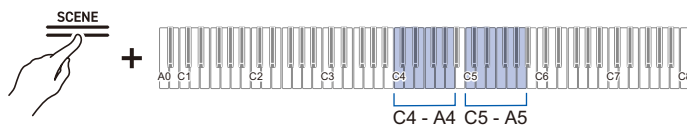

- For more information on preset scenes, see “[Preset Scene List](#)”.

Keyboard	Setting
C5	Default
C#5	Chopin
D5	Beethoven
Eb5	Mozart
E5	Debussy
F5	Liszt
F#5	Satie
G5	Baroque
Ab5	Lesson
A5	Concert

Keyboard	Setting
C4	User Scene 1
C#4	User Scene 2
D4	User Scene 3
E♭4	User Scene 4
E4	User Scene 5
F4	User Scene 6
F#4	User Scene 7
G4	User Scene 8
A♭4	User Scene 9
A4	User Scene 10

NOTE

- Pressing only the “SCENE” button will bring up the last recalled scene (default setting is preset scene 1).

Listening to the Sound Atmosphere of the Scene to Confirm (Scene Song)

You can play a few bars of a song appropriate for the scene so that you can listen and check the sound atmosphere of the selected scene.

- 1. Calls up a scene.**
 - See “[Calling Up a Scene](#)”.
- 2. Hold down the “SCENE” button and touch the “▶/■” button.**
- 3. Touch the “▶/■” button again to stop playback.**

NOTE

- If step 2 is performed when no scenes have been recalled since the Digital Piano was turned on, preset scene 1 will be recalled and the relevant scene song will be played.

Creating Your Own Scenes (User Scenes)

You can change the following items to create your own preferred settings and store them in the User Scenes.

- Tone Selection (including Layer and Split settings)
See "[Selecting a Tone](#)".
- Effects on sound (Sound Mode Effects, Acoustic Simulator, etc.)
See "[Applying Effects to Sound](#)".
- Scene Song
See "[Songs that can be Stored in User Scenes \(Scene Songs\)](#)".

For details on other settings stored in user scenes, see "[List of User Scene Record Items](#)".

Storing in User Scenes

1. Select tones, effects, etc., and create your own settings.
2. While holding down the "SCENE" button, press the B3 key (Store in User Scenes).

Putting in Standby Mode, and Executing on Next Key Press (operation type E)

- The Hall Simulator/Reverb Indicator and Surround Indicator will blink, and the Digital Piano will go on standby for saving to the User Scenes.
- Do not release the "SCENE" button until the next operation is complete.

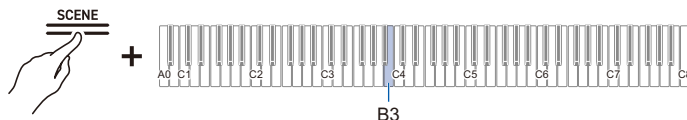

3. While holding down the "SCENE" button, press one of the C4 to A4 keys (User Scenes) to specify the user scene number to be stored.
 - If you specify a number for which a user scene has already been memorized, the user scene will be overwritten with the current settings.

Songs that can be Stored in User Scenes (Scene Songs)

The song that was selected at the time of saving is stored in the user scene.

The types of songs that can be stored in a user scene are as follows

- Music library (Built-in Songs, User Songs)
- MIDI Recorder Songs

Even if the original song data is deleted, the song data remains in the user scene.

NOTE

- Even if the [RePlayer/Recorder] setting is switched to a setting other than <MIDI Recorder> and stored in the user scene, the [RePlayer/Recorder] setting will always remain as <MIDI Recorder>. In this case, Music Library No. 1 is also stored as the scene song.

Listening to Songs

Types of Data that Can Be Played Back

This Digital Piano is equipped to play MIDI data (including built-in songs) and audio data.

■ MIDI Data

You can playback MIDI data stored in the Digital Piano's internal memory or USB flash drive.

For more information, see [“Playing MIDI Data”](#).

■ Audio Data

You can play back audio data stored in the Digital Piano's internal memory or USB flash drive.

For more information, see [“Playing Audio Data \(WAV, MP3\)”](#).



- Depending on the type of data you want to play back, you will need to switch the [RePlayer/Recorder] setting between <MIDI Recorder>, <Audio Recorder (USB Drv.)>, or <Audio Recorder (Internal)>.

Playing MIDI Data

■ Music Library

Use the Music Library to listen to and practice famous piano pieces.

Built-in Songs

These are 60 built-in songs (No.1 to 60 in the Music Library).

See [“Music Library List”](#) for song listings.

User Songs

These are 10 songs (No.61 to 70 in the Music Library) saved to the Digital Piano's internal memory from an external source. Saving User Songs is executed using a smart device or via a USB Flash Drive connected to the Digital Piano.

For details, see [“Using the Dedicated App”](#) and [“Loading a MIDI File from a USB Flash Drive into the Digital Piano”](#).

■ MIDI Recorder Songs

These songs are recorded with the Digital Piano's MIDI Recorder.

For more information, see [“Recording a Performance with the MIDI Recorder”](#).

■ USB Flash Drive Songs

A standard MIDI file (SMF format 0/1) or CASIO MIDI file (CMF format) song stored on a USB flash drive. You can easily play these back without loading them into the Digital Piano.

For saving MIDI data that can be played on this Digital Piano to a USB Flash Drive, see [“Copying MIDI Song Data to a USB Flash Drive Using a Computer”](#).

Switching to MIDI Recorder

The default setting for [RePlayer/Recorder] on this Digital Piano is <MIDI Recorder>.

While holding down the “FUNCTION” button, press the B3 key (MIDI Recorder).

Selecting a Setting Value Directly (operation type A)

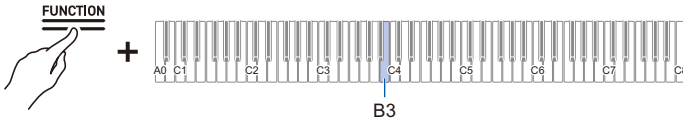

- The Visual Information Bar, second from left, will blink.

Selecting Songs for Playback from the Music Library

Operate with <MIDI Recorder>.

Switching to MIDI Recorder

- 1. Hold down the “▶/■” button and use the corresponding key to select a song. Once you have made your selection, release the “▶/■” button.**

- See “[Music Library List](#)” for song listings.

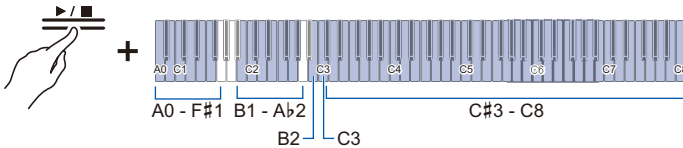

- Select a song assigned to a key (Built-in Songs: C#3 to C8 keys, User Songs: B1 to Ab2 keys)
[Selecting a Setting Value Directly \(operation type A\)](#)
- Specify song numbers (Built-in Songs: 1 to 60, User Songs: 61 to 70) using the A0 to F#1 keys
[Inputting Setting Values Using the Keys 0 to 9 \(operation type C\)](#)
- Use keys B2/C3 (Song Select –/Song Select +) to specify previous/next song (Built-in Songs, User Songs, MIDI Recorder Songs)
[Using the +/- Keys to Raise or Lower the Setting Value by 1 \(operation type B\)](#)

- 2. To start playback, touch the “▶/■” button.**

- To stop playback in the middle of a song, touch the “▶/■” button again.
- The beat indicator lights up in time with the beat of the song (left side for the first beat, right side for the remaining beats).
- Playback ends when the end of the song is reached.

NOTE

- If a song selection is made, the appropriate settings for the selected song is automatically implemented. Also, the playback settings return to default.

Selecting a MIDI Recorder Song for Playback

Operate with <MIDI Recorder>.

Switching to MIDI Recorder

1. While holding down the “▶/■” button, press the A2 key (MIDI Recorder Song).
Selecting a Setting Value Directly (operation type A)

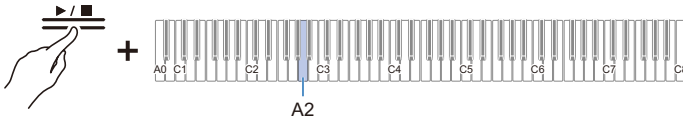

2. To start playing a song, touch the “▶/■” button.
 - To stop playback in the middle of a song, touch the “▶/■” button again.
 - Playback ends when the end of the song is reached.

Selecting a USB Flash Drive Song for Playback

Attach the USB flash drive containing the songs to the USB Type A port on the Digital Piano.

For information on using USB Flash Drives, see “Inserting/Removing a USB Flash Drive from the Digital Piano”.

Operate with <MIDI Recorder>.

Switching to MIDI Recorder

1. While holding down the “▶/■” button, press the B \flat 2 key (USB Flash Drive Song).
Switching On/Off or Changing Setting Values Using a Single Key (operation type D)

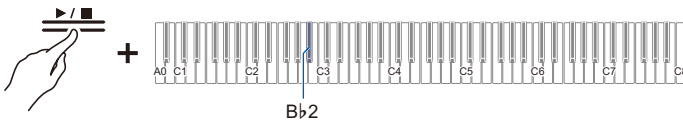

- Default value: Off

Setting Value	Setting Details
Off	Songs stored in the Digital Piano (Music Library songs, MIDI Recorder Song) are eligible for song selection
On	Songs stored on a USB flash drive (USB Flash Drive Songs) are eligible for song selection

- 2. Hold down the “▶/■” button and use the corresponding key to select a song. After selecting a song, touch the “▶/■” button.**

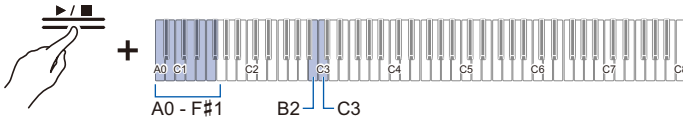

- Specify song numbers 0 to 99 using the A0 to F#1 keys (numbers 0 to 99 are automatically assigned to each file in ascending order of the file name).

[Inputting Setting Values Using the Keys 0 to 9 \(operation type C\)](#)

- Use keys B2/C3 (Song Select – /Song Select +) to specify previous/next song number

[Using the +/- Keys to Raise or Lower the Setting Value by 1 \(operation type B\)](#)

- 3. To start playback, touch the “▶/■” button.**

- To stop playback in the middle of a song, touch the “▶/■” button again.
- The beat indicator lights up in time with the beat of the song (left side for the first beat, right side for the remaining beats).
- Playback ends when the end of the song is reached.

NOTE

- If the file of the specified song number does not exist, a tone will sound for invalid.

Changing the Tempo

Select the song to be played before changing the setting.

1. While holding down the “SCENE” button, press the corresponding key.

- Sets the tempo in the range of 20 to 255 (beats per minute).

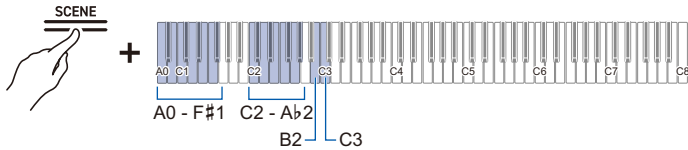

Entering Tempo as a Number

Raising or Lowering the Tempo Value by 1

Setting the Tempo from a Tempo Marking

2. To start playback, touch the “▶/■” button.

NOTE

- The tempo setting can be changed even during playback.
- In some songs, the tempo changes in the middle of the song for expression within the performance.

Selecting a Playback Part

You can mute the right-hand or left-hand part of a song and practice playing it yourself.

- Select the song to be played before changing the setting.
- Set the tempo as needed.

For more information, see “[Changing the Tempo](#)”.

1. While holding down the “▶/■” button, press the B \flat 1 key (Song Playback Part selection (LR/L/R)).

Switching On/Off or Changing Setting Values Using a Single Key (operation type D)

- The “L” and “R” track indicators light up respectively.

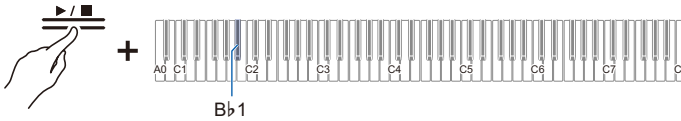

Track Indicator	Setting Details
Only L lights up	Plays the left-hand part and mutes the right-hand part.
Only R lights up	Plays the right-hand part and mutes the left-hand part.
Both L and R light up	Both left and right parts are played back.

2. To start playback, touch the “▶/■” button.

NOTE

- When playing a standard MIDI file (SMF format), ch3 will be the left-hand part and ch4 will be the right-hand part.

Playing Audio Data (WAV, MP3)

Data that Can be Played Back

The following audio data can be played.

- Audio data stored in the internal memory of the Digital Piano
- Audio data in the AUDIOREC folder stored on a USB flash drive can be played back.

Supported audio data formats are as follows.

- WAV files (linear PCM, 16bit, 44.1kHz, stereo, extension: .WAV), file name "TAKE**.WAV" (where ** = 01-99)
- MP3 files (MPEG-1 Audio Layer3, 44.1kHz/48kHz, bit rate 32-320kbps/variable bit rate (VBR) supported, mono/stereo, extension: .MP3), file name "TAKE**.MP3" (where ** = 01-99)

NOTE

- For saving audio data that can be played on this Digital Piano to a USB flash drive, see "[Copying Audio Data \(WAV, MP3\) to a USB Flash Drive Using a Computer](#)".

Switching to Audio Recorder

Switch the [RePlayer/Recorder] setting to one of the following.

When playing this:	Switch to this setting:
Audio data stored on USB flash drive	Audio Recorder (USB Drv.)
Audio data stored in internal memory	Audio Recorder (Internal)

■ Switch to <Audio Recorder (USB Drv.)>

1. Attach the USB Flash Drive containing the songs to the USB Type A port on the Digital Piano.
 - For information on using USB Flash Drive, see "[Inserting/Removing a USB Flash Drive from the Digital Piano](#)".
2. While holding down the "FUNCTION" button, press the C4 key.

Selecting a Setting Value Directly (operation type A)

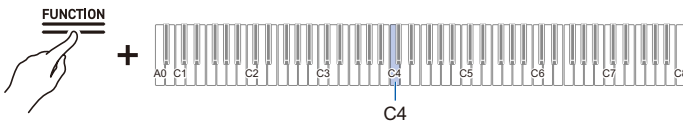

- On the Visual Information Bar, the third light from the left will blink.

■ Switch to <Audio Recorder (Internal)>

While holding down the “FUNCTION” button, press the D4 key.

Selecting a Setting Value Directly (operation type A)

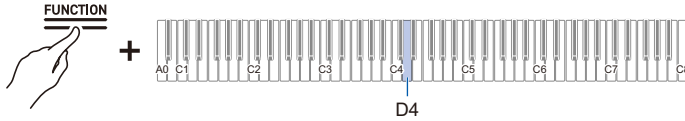

- On the Visual Information Bar, the fifth light from the left will blink.

Selecting a Song for Playback

Use <Audio Recorder (USB Drv.) > or <Audio Recorder (Internal)>.

Switching to Audio Recorder

1. Hold down the “▶/■” button and use the corresponding key to select a song. After selecting a song, release the “▶/■” button.

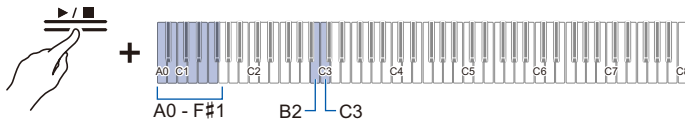

- Use the A0 to F#1 keys to specify the TAKE**.WAV (where ** =01-99) number.
Inputting Setting Values Using the Keys 0 to 9 (operation type C)
 - Use keys B2/C3 (Song Select – /Song Select +) to specify previous/next song number
Using the +/- Keys to Raise or Lower the Setting Value by 1 (operation type B)
2. To start playback, touch the “▶/■” button. To stop playback in the middle of a song, touch the “▶/■” button again.
 - Playback ends when the end of the song is reached.

NOTE

- If the file of the specified song number does not exist, a tone will sound to indicate that the selection is invalid.
- When “Audio Recorder (USB Drv.)” is selected and the WAV file name “TAKE**.WAV” (where ** = 01–99) and the MP3 file name “TAKE**.MP3” (where ** = 01–99) are the same, the WAV file will play.

Recording a Performance

MIDI Recorder and Audio Recorder Features

The Digital Piano has two recording options: a MIDI Recorder and an Audio Recorder. Depending on the type of data you want to record or play back, you will need to switch the [RePlayer/Recorder] setting between <MIDI Recorder>, <Audio Recorder (USB Drv.)>, or <Audio Recorder (Internal)>.

Recording Features

■ MIDI Recorder

Performances are converted to MIDI data* and recorded to two tracks (data domain where performances are recorded) in the internal memory.

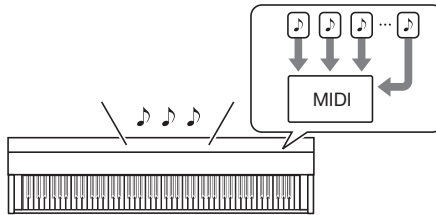

- Keyboard performance information (keys pressed and released, touch strength, etc.) is recorded as MIDI data.
- MIDI data has the benefit of being extremely small in size compared to audio data, and it can be edited later, e.g., on a computer.
- One song can be recorded. When a new recording is made, the previous recording is erased.
- The maximum number of notes that can be recorded in one song is approximately 30,000 notes as a total for both tracks.

* MIDI

MIDI is an abbreviation for Musical Instrument Digital Interface. It is a unified standard that allows performance information (keys pressed and released, touch strength, etc.) to be exchanged between electronic musical instruments or between electronic musical instruments and computer equipment, regardless of manufacturer. The performance information exchanged is called MIDI data.

You can also:

Record to the right-hand part track while playing the left-hand part track

Left-hand part track

Keyboard performance

While playing back

Right-hand part track

Keyboard performance



■ Audio Recorder

Record your performance as audio data* to the internal memory or a USB flash drive.

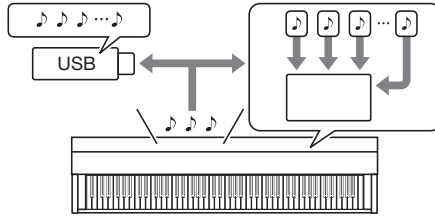

- The sound itself is recorded as audio data, similar to recording on a portable music player or tape recorder.
- Audio data files are extremely large in size compared to MIDI data. However, they have the advantage of being easy to listen to on a computer or portable music player.
- The internal memory can record up to approximately 18 minutes and up to 99 files (the total of all files must not exceed 18 minutes).
- Up to 25 minutes and up to 99 files can be recorded on a USB Flash Drive.

* Audio Data

Audio data recorded with this Digital Piano is saved in WAV file format (linear PCM, 16 bit, 44.1 kHz, stereo).

You can also:

Record a performance while playing back a song recorded using the MIDI Recorder



NOTE

- For information about data file formats that are supported by this Digital Piano, see “[Types of Data that Can be Handled by this Digital Piano](#)”.
- Data recorded on the Digital Piano can be saved to a USB Flash Drive. See “[Saving MIDI Recorder Songs to a USB Flash Drive](#)” and “[Save a Batch of Audio Files from the Internal Memory to a USB Flash Drive](#)”.

Playback Features

■ MIDI Recorder

Plays the left-hand part track and the right-hand part track (both or either).

- The MIDI Recorder automatically plays the internal sound source of this Digital Piano according to the performance information recorded as MIDI data.

You can also:

Play the keyboard along with playback of the left-hand part track and the right-hand part track

Left-hand part track

While playing back

Right-hand part track

While playing back

Keyboard performance

Change the Tempo of a Recording

You can, for example, record at a slower tempo and play back at a faster tempo.

- The tempo set for the left-hand part track is applied to the right-hand part track.

■ Audio Recorder

Play audio data from internal memory or USB flash drive.

- The Audio Recorder plays back the actual sound waveform, which is recorded as audio data.

You can also:

Perform on the keyboard while playing audio data

Play audio data



Keyboard Performance



NOTE

- For information about data file formats that are supported by this Digital Piano, see [“Types of Data that Can be Handled by this Digital Piano”](#).

Recording a Performance with the MIDI Recorder

Records keyboard performances and pedal usage as MIDI data.

! IMPORTANT!

- Be aware that we will not be responsible for any damages, lost profits, or any claims from third parties arising from the deletion of recorded content due to malfunction or repair of this Digital Piano.

Main Content Recorded by the MIDI Recorder

When recording with the MIDI Recorder, the following operations and settings are recorded to the Digital Piano's internal memory.

- Keyboard and pedal play
- Tone
- Tempo*
- Beat*
- Keyboard volume*
- Layer settings (left-hand part track only)
- Split settings (left-hand part track only)
- Duet (left-hand part track only)
- Sound Mode (Hall Simulator/Reverb Type, Hall Simulator/Reverb depth for built-in sound source, Surround Type), Chorus, Brilliance*
- Acoustic Simulator settings*
- Scale Tuning*
- Stretch Tuning*

* Left-hand part track only. However, the setting is also applied to the right-hand part track during playback.

Preparing to Use the MIDI Recorder

Switch the [RePlayer/Recorder] setting to <MIDI Recorder>.

The default setting for [RePlayer/Recorder] on this Digital Piano is <MIDI Recorder>.

While holding down the “FUNCTION” button, press the B3 key (MIDI Recorder).

[Selecting a Setting Value Directly \(operation type A\)](#)

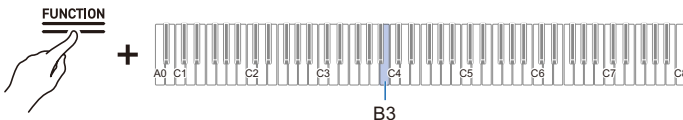

- The Visual Information Bar, second from left, will blink.

NOTE

- This Digital Piano features mainly three different [RePlayer/Recorder] function operations: MIDI Recorder, Audio Recorder, and Instant RePlayer. Note, however, that only one of them will work at a time.

Recording

■ Easy use of MIDI Recorder

1. **Touch the “●(REC)” button (lit white).**
 - The “●(REC)” button will start to blink red to indicate that recording is on standby.
2. **When you start to play, recording will begin automatically.**
 - The “●(REC)” button stops blinking red and changes to lit to indicate that recording is in progress.
3. **To end recording, touch the “●(REC)” button.**
 - The “●(REC)” button will light up white again.
4. **To play the current recording, touch the “▶/■” button.**
 - To stop playback, touch the “▶/■” button again.

■ Recording to the Left-Hand Part Track

Switch [RePlayer/Recorder] to <MIDI Recorder> for operation.

[Preparing to Use the MIDI Recorder](#)

1. **Set tones, effects, tempo, etc. for recording as necessary.**
 - For setting beat and tempo, see [“Setting the Beat”](#) and [“Setting a Tempo”](#).
 - For track-by-track recording details, see [“Main Content Recorded by the MIDI Recorder”](#).
2. **Touch the “●(REC)” button (lit white).**
 - Recording goes to standby, and the “●(REC)” button blinks red.
 - The “L” Track Indicator blinks.
 - To stop the recording, touch the “●(REC)” button again.



3. **To sound the metronome while recording, touch the “METRONOME” button.**

4. Recording will begin when you start playing.

- You can also start recording by holding down the “●(REC)” button and touching the “▶/■” button.
- The “●(REC)” button switches from blinking to lit, and the “▶/■” button goes off.
- If you want to redo your recording, see “Starting over from the beginning during a recording”.

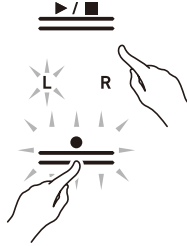

5. To end recording, touch the “●(REC)” button.

- The “●(REC)” button will light up white again and the “▶/■” button will light up.
- To play back the recording immediately, touch the “▶/■” button.

Starting over from the beginning during a recording

If you want to redo the recording due to a performance error or other reason, hold down the “●(REC)” button until it flashes during recording. The recorded data is discarded and the process returns to a record standby state.

■ Overdub Recording (record to the right-hand part track to layer over the recording of the left-hand part track)

Use “[Recording to the Left-Hand Part Track](#)” to enter the record standby state before proceeding.

1. Touch and hold the “●(REC)” button until the “R” Track Indicator flashes.

- The right-hand part track will be recorded.
- The “L” in the track indicator switches from a blink to lit.



2. If you do not want the left-hand part track to play during recording, hold down the “▶/■” button and press the B♭1 key (Song Playback Part selection).

Switching On/Off or Changing Setting Values Using a Single Key (operation type D)

- The “L” Track Indicator goes off.
- Each time B♭1 key is pressed, the “L” Track Indicator switches between lit (Playback) and unlit (No Playback).

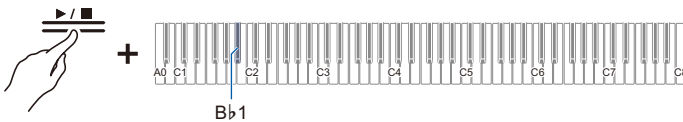

3. Next, proceed from step 4, “[Recording to the Left-Hand Part Track](#)”.

NOTE

- Some settings recorded for the left hand part track, including beat and tempo, are also applied to the right hand part track recording.

Erasing the Recording of a Track

Operate with <MIDI Recorder>.

[Preparing to Use the MIDI Recorder](#)

- 1. Touch the “●(REC)” button (lit white).**
 - Recording goes to standby, and the “●(REC)” button blinks red.
 - The “L” in the track indicator will blink, and the left-hand part track will be erased.



- 2. To erase the right hand-part track, press and hold the “●(REC)” button until the “R” Track Indicator blinks.**
- 3. While holding down the “●(REC)” button, touch the “▶/■” button.**
 - The “●(REC)” button switches from blinking to lit.
- 4. Hold down the “●(REC)” button until it blinks.**
 - The recording of the specified track will be erased.
- 5. Touch the “●(REC)” button to exit record standby.**

Recording a Performance with the Audio Recorder

Keyboard performances and pedal usage are recorded as audio data. Recordings are saved in WAV file (linear PCM, 16bit, 44.1kHz, stereo) format to a USB flash drive connected to the USB Type A port or to the built-in flash memory.

Preparing to Use the Audio Recorder

Switch the [RePlayer/Recorder] setting to one of the following.

When doing this:	Switch to this setting:
Direct Recording to USB Flash Drive Delete USB Flash Drive Files	Audio Recorder (USB Drv.)
Recording to internal memory Manipulating files in internal memory	Audio Recorder (Internal)

■ Switching to <Audio Recorder (USB Drv.)>

1. Attach the USB flash drive to the USB Type A port on the Digital Piano.

- For information on using USB flash drives, see “[Inserting/Removing a USB Flash Drive from the Digital Piano](#)”.

2. While holding down the “FUNCTION” button, press the C4 key.

[Selecting a Setting Value Directly \(operation type A\)](#)

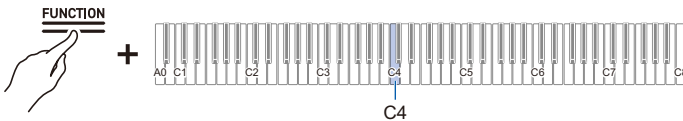

- The Visual Information Bar, third from the left, will blink.

! IMPORTANT!

- If the [RePlayer/Recorder] setting is <Audio Recorder (USB Drv.)>, do not remove the USB flash drive during recording or playback. Doing so can corrupt the data on the USB flash drive and damage the USB Type A port.
- For more information on using USB flash drives, see “[Using a USB Flash Drive](#)”.
- For supported USB Flash Drive formats, see “[Supported USB Flash Drives](#)”.

NOTE

- This Digital Piano features mainly three different [RePlayer/Recorder] function operations: MIDI Recorder, Audio Recorder, and Instant RePlayer. Note, however, that only one of them will work at a time.

■ Switching to <Audio Recorder (Internal)>

While holding down the “FUNCTION” button, press the D4 key (Audio Recorder).

Selecting a Setting Value Directly (operation type A)

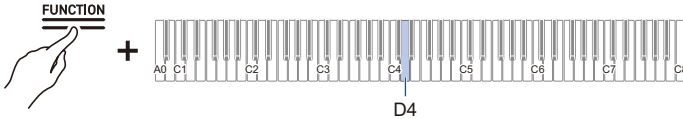

- On the Visual Information Bar, the fifth light from the left will blink.

Recording an Audio Recorder Song (WAV)

Use <Audio Recorder (USB Drv.) > or <Audio Recorder (Internal)>.

Preparing to Use the Audio Recorder

1. Touch the “●(REC)” button (lit white).

- Recording goes to standby, and the “●(REC)” button blinks red.
- To stop the recording, touch the “●(REC)” button again.



- When the Audio Recorder (Internal) is used, the Visual Information Bar displays the approximate amount of available recording space. Depending on the amount of memory used, the area lit from the left side of the Visual Information Bar will increase, and when the entire bar is lit, recording will no longer be possible.

2. Recording will begin when you start playing.

- You can also start recording by holding down the “●(REC)” button and touching the “▶/■” button.
- The “●(REC)” button switches from flashing to lit, and the “▶/■” button goes off.

3. To end recording, touch the “●(REC)” button.

- The “●(REC)” button will light up white again and the “▶/■” button will light up.

4. To play the recording, touch the “▶/■” button.

NOTE

- The possible recording times and number of files are shown in the table below.

When recording to a USB Flash Drive	Each file can be recorded for up to approximately 25 minutes, and up to 99 files can be recorded (however, this depends on the available capacity of the USB Flash Drive used).
When recording to internal memory	If there is no data already in the internal memory, the maximum recording time is about 18 minutes. Up to 99 files can be recorded within a total recording time range of approximately 18 minutes.

- Recording will automatically end when the available recording time has elapsed. The “●(REC)” button will start blinking when there is limited time left for recording.
- The Digital Piano’s Audio Recorder records in WAV format. Recording in MP3 format is not supported (playback of MP3 files copied from a computer to a USB Flash Drive or MP3 files loaded from a USB Flash Drive to the Digital Piano’s internal memory is supported).
- Recordings are saved in the order of the destination memory (internal memory or USB Flash Drive) with file names from “TAKE01.WAV” to “TAKE99.WAV.” The file name is the last number of either the WAV or MP3 file in the destination memory, plus one. (e.g. If you currently have two files TAKE01.WAV and TAKE03.MP3 in the destination memory, the recording will be saved with the file name TAKE04.WAV).

■ When you want to start over from the beginning during a recording

If you want to redo the recording due to a performance error or other reason, hold down the “●(REC)” button until it flashes during recording. The recorded data is discarded and the process returns to a record standby state.

Recording to the Audio Recorder while Playing Back Data Recorded to the MIDI Recorder

1. While holding down the “FUNCTION” button, press C#4 (USB Flash Drive) or E♭4 key (internal flash memory).

Selecting a Setting Value Directly (operation type A)

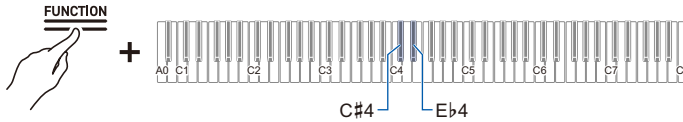

Keyboard	Setting
C#4	Audio Rec with MIDI playback (USB Flash Drive)
E♭4	Audio Rec with MIDI playback (internal flash memory)

- The Visual Information Bar will display the following.
When recording to USB Flash Drive: The third light from the right will flash.
When recording to internal flash memory: The rightmost light will flash.

2. If you pressed the C#4 key (USB Flash Drive) in step 1, attach the USB Flash Drive to the USB Type A port on the Digital Piano.
3. Touch the “●(REC)” button (lit white).
 - Recording goes to standby, and the “●(REC)” button blinks red.
 - The track indicator of the part being recorded with the MIDI Recorder will light up.



4. To set the playback part, hold down the “▶/■” button and press the B♭1 key (Song Playback Part selection).

Switching On/Off or Changing Setting Values Using a Single Key (operation type D)

- The “L” and “R” track indicators light up respectively.

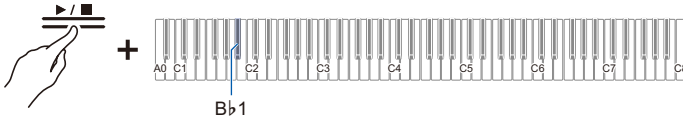

Track Indicator	Setting Details
Only L lights up	Plays the left-hand part and mutes the right-hand part.
Only R lights up	Plays the right-hand part and mutes the left-hand part.
Both L and R light up	Both left and right parts are played back.

5. Recording will begin when you start playing.

- The MIDI Recorder Song will play as recording begins.
- You can also start recording by holding down the “●(REC)” button and touching the “▶/■” button.
- The beat indicator lights up in time with the beat.
- If you want to redo your recording, see “[When you want to start over from the beginning during a recording](#)”.

6. To end recording, touch the “●(REC)” button.

- The “●(REC)” button will light up white again and the “▶/■” button will light up.
- To play the recording immediately, touch the “▶/■” button.

 **NOTE**

- The possible recording times and number of files are shown in the table below.

When recording to a USB Flash Drive	Each file can be recorded for up to approximately 25 minutes, and up to 99 files can be recorded (however, this depends on the available capacity of the USB Flash Drive used).
When recording to internal memory	If there is no data already in the internal memory, the maximum recording time is about 18 minutes. Up to 99 files can be recorded within a total recording time range of approximately 18 minutes.

- Recording will automatically end when the available recording time has elapsed. The “●(REC)” button will start blinking when there is limited time left for recording.
- The Digital Piano’s Audio Recorder records in WAV format. Recording in MP3 format is not supported (playback of MP3 files copied from a computer to a USB Flash Drive or MP3 files loaded from a USB Flash Drive to the Digital Piano’s internal memory is supported).
- Recordings are saved in the order of the destination memory (internal memory or USB Flash Drive) with file names from “TAKE01.WAV” to “TAKE99.WAV.” The file name is the last number of either the WAV or MP3 file in the destination memory, plus one. (e.g. If you currently have two files TAKE01.WAV and TAKE03.MP3 in the destination memory, the recording will be saved with the file name TAKE04.WAV).

Deleting Audio Files from a USB Flash Drive

Use <Audio Recorder (USB Drv.)>.

[Preparing to Use the Audio Recorder](#)

1. Hold down the “▶/■” button and select the file to be deleted with the corresponding key.

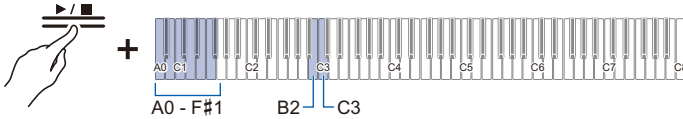

- Use the A0 to F#1 keys to specify the TAKE**.WAV (** is 01-99) number
[Inputting Setting Values Using the Keys 0 to 9 \(operation type C\)](#)
- Use keys B2/C3 (Song Select – /Song Select +) to specify previous/next song number
[Using the +/- Keys to Raise or Lower the Setting Value by 1 \(operation type B\)](#)

2. While holding down the “FUNCTION” button, press the B1 key (Delete SMF/MRF/ Audio).

[Putting in Standby Mode, and Executing on Next Key Press \(operation type E\)](#)

- Do not release the “FUNCTION” button until the next operation is complete.

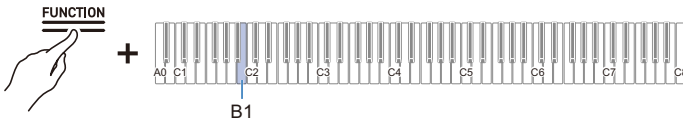

3. While holding down the “FUNCTION” button, press the C1 key (Execute).

- The file is deleted.

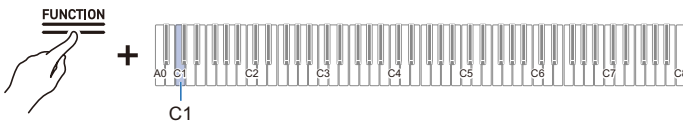

NOTE

- The number specified for deletion applies to both WAV and MP3 files. If a WAV file and MP3 file share the same number, they will both be deleted.

Erasing the Last Audio File Numbered in the Internal Memory

1. While holding down the “FUNCTION” button, press the C#2 key (Clear Audio).
 Putting in Standby Mode, and Executing on Next Key Press (operation type E)
 - Do not release the “FUNCTION” button until the next operation is complete.

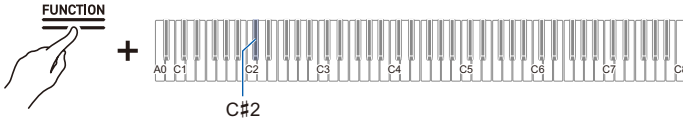

2. While holding down the “FUNCTION” button, press the C1 key (Execute).
 - Deletion will take place.

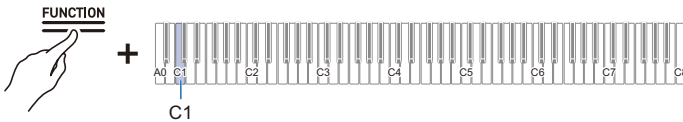

Erasing All Audio Files in the Internal Memory

1. While holding down the “FUNCTION” button, press the D2 key (Clear All Audio).
 Putting in Standby Mode, and Executing on Next Key Press (operation type E)
 - Do not release the “FUNCTION” button until the next operation is complete.

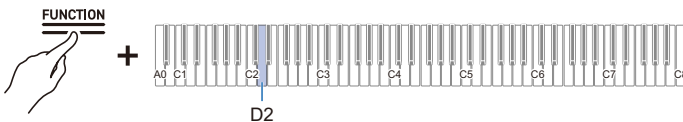

2. While holding down the “FUNCTION” button, press the C1 key (Execute).
 - Deletion will take place.

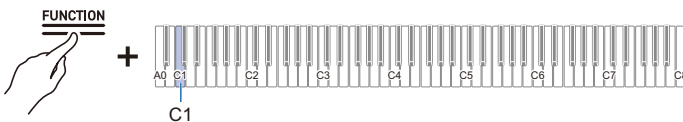

Listening back to a Performance Immediately (Instant RePlayer)

Instant RePlayer

When practicing, you may be so focused on looking at the sheet music and playing the correct keys that it is difficult to evaluate your performance as well.

The Instant RePlayer function allows you to easily listen back (replay) to a recording of a performance you just played, making it easy to evaluate your own performances.

Instant RePlayer Features

Performance is automatically recorded.

- You can easily listen back to a performance by simply using replay.
- You can replay up to the last 270 seconds of a performance.
- You can specify the point from which to replay.
- If you make a mark in a performance, replay can be started from the position you marked.

IMPORTANT!

- In addition to the “Instant RePlayer” described this section, the [RePlayer/Recorder] function includes other recording functions, “MIDI Recorder” and “Audio Recorder”. Each of these functions has its own unique features. You can select from any one of these recording functions to use (at a time only the one you selected will work).
- Instant RePlayer recordings will be cleared if you change anything other than the metronome setting or turn off the Digital Piano.
- Instant RePlayer records keyboard and pedal operation and metronome sounds.

Preparing to Use the Instant RePlayer

Switch the [RePlayer/Recorder] setting to <Instant RePlayer>.

While holding down the “FUNCTION” button, press the B \flat 3 key (Instant RePlayer).

Selecting a Setting Value Directly (operation type A)

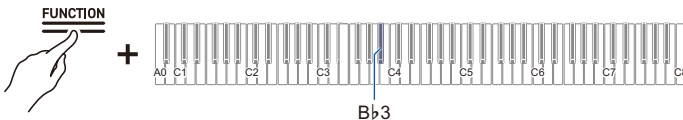

- The Visual Information Bar blinks at the left end.

IMPORTANT!

- When the [RePlayer/Recorder] is set to <Instant RePlayer>, the Instant RePlayer is always running.
- If you do not want the Instant RePlayer to work, switch the [RePlayer/Recorder] setting to something other than <Instant RePlayer> (such as <MIDI Recorder>).

For details on how to change the [RePlayer/Recorder] setting to <MIDI Recorder>, see “Preparing to Use the MIDI Recorder”.

Simple Usage

1. Start performing.

- Recording starts and the “●(REC)” button blinks slowly to indicate that recording is in progress.

2. To replay, stop your performance and touch the “▶/■” button.

- Replay starts from the note played 10 seconds before the last note played. Replay stops when replayed to the end.
- When you want to stop the replay midway, touch the “▶/■” button. Once stopped, touch the “▶/■” button if you wish to start replay again.
- Although notes played within 10 seconds of the last note are played, notes played on keys pressed more than 10 seconds ago will not be played.

3. After replay is finished, return to step 1.

- Recording starts when the next performance begins.

NOTE

- To start the replay, you can simply press the “▶/■” button to specify 10 seconds earlier, or you can specify a marked position and the number of seconds to go back. For more information, see [“Listen Back Using Marks”](#) and [“Listen Back Using Specified Number of Seconds”](#).
- The maximum recording time is 270 seconds, and when this is exceeded, the oldest performance will be overwritten, meaning you can only listen back to the most recent 270 seconds of a performance.
- While the Instant RePlayer is recording (the “●(REC)” button blinks slowly), press and hold the “●(REC)” button (for 2 seconds) to clear all 270 seconds of the recording.

Listen Back Using Marks

What is a Mark?

If you place a cue mark at the desired time during performance, you can start playback from the marked position upon replay. You can add up to 36 marks (within 270 seconds), and specify from which mark position to start replay.

Performing

Start performing.

- The “●(REC)” button blinks slowly to indicate that recording is in progress.
- When you turn on the power and use the Instant RePlayer for the first time, marks are automatically added.

Adding Marks at Desired Points within Performances

Touch the “●(REC)” button at the point you wish to cue a replay.

- The mark is added when the “●(REC)” button is touched.
- When you add a mark, recording will stop temporarily (the “●(REC)” button light will go out), and recording begins (the “●(REC)” button blinks slowly) from the point at which the next performance starts (key press or pedal operation).

Replaying from a Mark

1. Stop playing, hold down the “▶/■” button, and press a black key for mark selection to specify the mark at which you wish to start replay.

Selecting a Setting Value Directly (operation type A)

- Replay starts from the specified mark position.
- For the black keys assigned to mark selection, see “Start mark and start seconds for Instant RePlayer”.

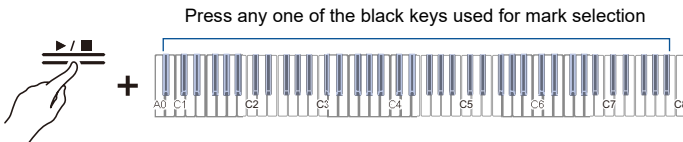

2. When the replay is over, start the next performance.

- When the next performance begins, a mark is automatically placed at that position.

NOTE

- If you specify a mark that does not exist, the oldest mark is selected for replay.

■ Example of specifying a mark

When you want to start replay from the newest position (last marked position)

While holding down the “▶/■” button, press the B_b0 key (Replay start mark (Most recent)).

Selecting a Setting Value Directly (operation type A)

- Replay starts from the most recent cue mark.

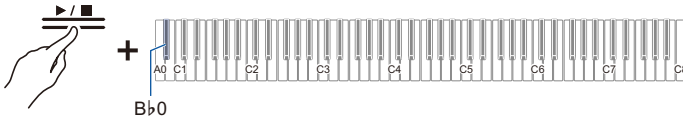

When you want to start replay from a marked position made 10 times earlier

While holding down the “▶/■” button, press the B_b2 key (Replay start mark (10 times back)).

Selecting a Setting Value Directly (operation type A)

- Starts the replay with a cue for the mark position made 10 times ago.

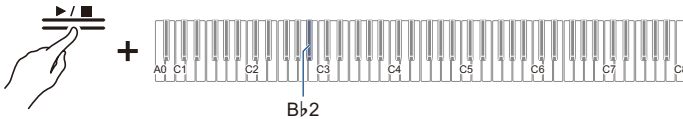

Listen Back Using Specified Number of Seconds

Touching the “▶/■” button during replay will start replay 10 seconds before the last note you played, but it is possible to replay from even earlier than 10 seconds back. For earlier than 10 seconds, you can specify the number of seconds to start replay in 5-second increments.

1. Start performance.

- While recording, the “●(REC)” button blinks slowly.

2. To replay, stop playing and hold down the “▶/■” button and press the white key that specifies the number of seconds to return and start replay from to specify the number of desired seconds.

Selecting a Setting Value Directly (operation type A)

- Replays the performance from the note played a specified number of seconds before to the last note played.
- For the white keys that specify the amount of seconds to return and start from, see “[Start mark and start seconds for Instant RePlayer](#)”.

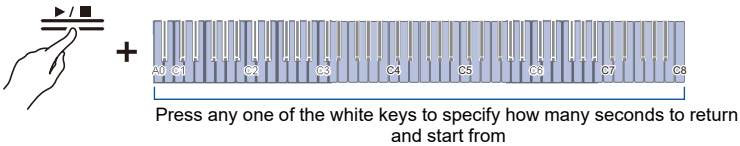

3. After replay, begin the next performance.

NOTE

- If recording is shorter than 270 seconds, replay will start from the oldest recording position when you specify a number of seconds that is prior the oldest recording.

■ Example of specifying the number of seconds to return back to

When you want replay to start 60 seconds back in time:

While holding down the “▶/■” button, press the C2 key (number of seconds to return and replay from (60 seconds back in time)).

[Selecting a Setting Value Directly \(operation type A\)](#)

- Starts replay by cueing up 60 seconds back in time.

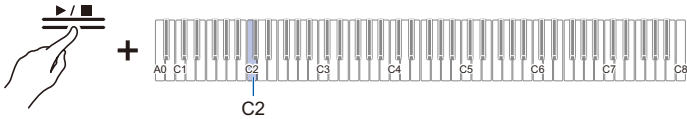

Using a USB Flash Drive

Using a Commercially Available USB Flash Drive – What You Can Do

You can do the following using a commercially available USB flash drive.

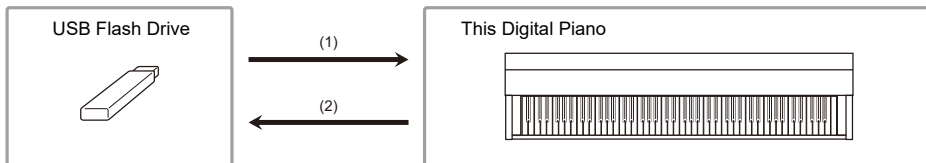

(1) Using a file on a USB Flash Drive with this Digital Piano

- Direct playback of audio files from a USB flash drive
For more information, see [“Playing Audio Data \(WAV, MP3\)”](#).
- Direct playback of MIDI files on a USB flash drive
For more information, see [“Playing MIDI Data”](#).
- Load compatible files from a USB flash drive into the Digital Piano
For details, see [“Loading a MIDI File from a USB Flash Drive into the Digital Piano”](#), [“Loading Audio Files from a USB Flash Drive onto the Digital Piano in Batches”](#), and [“Loading a User Scene File Saved on a USB Flash Drive onto this Digital Piano”](#).
- Deleting USB Flash Drive Files
For details, see [“Deleting MIDI or Audio Files from a USB Flash Drive”](#) and [“Delete user scene files on a USB flash drive”](#).

(2) Save performances or data stored on the Digital Piano to a USB flash drive

- Record Audio Recorder songs (WAV) directly to a USB flash drive
For more information, see [“Recording an Audio Recorder Song \(WAV\)”](#).
- Saving data from the Digital Piano to a USB flash drive
For details, see [“Saving MIDI Recorder Songs to a USB Flash Drive”](#), [“Save a Batch of Audio Files from the Internal Memory to a USB Flash Drive”](#), and [“Saving User Scenes to a USB Flash Drive”](#).

Preparing a USB Flash Drive

Supported USB Flash Drives

Use FAT32 or exFAT formatted USB flash drives.

- For USB flash drives with large capacities, mounting and formatting may take some time.
- Depending on the performance and characteristics of the USB flash drive, it may not be possible to correctly perform recording/playback.

IMPORTANT!

- **It may not be possible to use USB flash drives that are recognized as multiple drives on a computer.**
- **USB flash drives that are recognized as CD-ROMs on a computer cannot be used.**
- **USB flash drives with special functions, such as anti-virus or security features, cannot be used.**

Types of Data that Can be Handled by this Digital Piano

■ Audio data

WAV format

A standard audio file format used primarily in Windows. This Digital Piano is compatible with Linear PCM, 16 bit, 44.1 kHz, stereo WAV files (extension: .WAV).

MP3 format

A common audio file format widely used for music distribution. This Digital Piano supports 44.1/48 kHz, 32–320 kbps bit rate, and variable bit rate (VBR) compatible MP3 files (extension: .MP3).

■ MIDI data

MRF format (CASIO's original file format)

MIDI data recorded by the Digital Piano's MIDI Recorder (extension: .MRF).

CMF format (CASIO's original file format)

CASIO's own MIDI data to which performance information is added (extension: .CMF).

SMF (Standard MIDI File) format, Format 0/1:

Standard MIDI file format compatible with MIDI equipment from other manufacturers (extension: .MID).

Data Type		Extension	Save (Internal memory → USB flash drive)	Load (USB flash drive → internal memory)	Direct recording to USB flash drive	Playback directly from USB flash drive
Audio	Audio Recorder Song File	.WAV	✓	✓	✓	✓
	General Audio File	.WAV	✓*1		–	
		.MP3		–		
MIDI	MIDI Recorder Song File	.MRF	✓*2	✓	–	–
	CASIO MIDI File	.CMF	–	✓*3	–	✓
	Standard MIDI file (SMF format)	.MID				
Scene	User scene file	.SCS	✓	✓	–	–

*1 WAV and MP3 files loaded from a USB flash drive to the Digital Piano's internal memory can be saved directly from the internal memory to the USB flash drive.

*2 They can also be converted to a standard MIDI file (SMF format 0, extension: .MID) and saved.

- When saving in MRF format

Not only performance information, but also settings for functions specific to this Digital Piano (such as Acoustic Simulator settings) are saved. When a file saved in this format is played back on the Digital Piano, the original performance is reproduced. However, MRF files cannot be used with other instruments.

- When saving in SMF format

Performance information is saved, but the settings for the Digital Piano-specific functions are not. Therefore, even if a file saved in this format is played back on this Digital Piano, the Digital Piano-specific settings of the Digital Piano's functions are not restored to their original settings. However, files saved in this format can be used with other SMF-compatible instruments. (It is not possible to reproduce the same performance from this Digital Piano on other instruments.)

*3 Loaded as a User Song (song numbers 61-70). See "[Loading a MIDI File from a USB Flash Drive into the Digital Piano](#)".

Copyrights

You are allowed to use recordings for your own personal use. Any reproduction of an audio or music format file, without the permission of its copyright holder, is strictly prohibited under copyright laws and international treaties. Also, making such files available on the Internet or distributing them to third parties, regardless of whether such activities are conducted with or without compensation, is strictly prohibited under copyright laws and international treaties. CASIO COMPUTER CO., LTD. shall not be held in any way liable for any use of this Digital Piano that is illegal under copyright laws.

Inserting/Removing a USB Flash Drive from the Digital Piano

- Follow the precautions in the instructions that are supplied with the USB flash drive.
- Avoid storing or using the product in the places outlined below. Data on the USB flash drive may be corrupted.
 - Locations with high temperature, humidity, or corrosive conditions
 - Locations prone to strong static electricity or electrical noise
- Do not operate the Digital Piano or remove the USB flash drive while data is being saved or loaded. Doing so can corrupt the data on the USB flash drive and damage the USB Type A port.
- Never insert devices other than those specified in this manual into the USB Type A port. Doing so may cause a malfunction.
- When operating a USB flash drive for the first time after it is inserted into the Digital Piano, or when operating a USB flash drive for the first time after turning on the power, the Digital Piano may become temporarily inoperable as the system prepares to exchange data with the USB flash drive (mounting).
- Mounting is executed each time a USB flash drive is inserted into the Digital Piano.
- During mounting, the indicators above the “SOUND MODE” and “▶/■” buttons will light up sequentially, and the Visual Information Bar will indicate that it is in progress (lighting sequentially from the left). Do not operate the Digital Piano while it is mounting.
- It may take tens of seconds to several minutes for the monitoring system to complete mounting and become operational.

■ Insertion

Insert the USB flash drive into the USB Type A port of the Digital Piano.

- Make sure to fully insert the drive. Do not insert the drive forcibly.

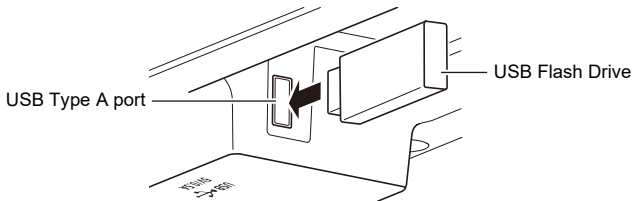

- The Digital Piano may malfunction if static electricity is transferred to the USB Type A port from your hand or a USB flash drive. If this happens, turn the Digital Piano off and then back on again.

■ Removal

Make sure that no data is being exchanged between the Digital Piano and the USB flash drive, before unplugging and removing the USB flash drive.

- After prolonged use, the USB flash drive, which was removed, may be warm, but this is not a malfunction.

Formatting a USB Flash Drive

When a USB flash drive is formatted in this Digital Piano, a folder named “CASIO” is created in the root directory. This folder is always used when exchanging data between the Digital Piano and the USB flash drive.

Diagram of the USB flash drive folder structure:

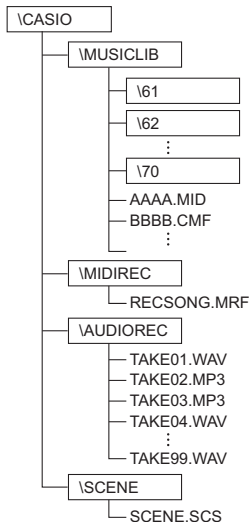

IMPORTANT!

- **Be sure to format the USB flash drive on the Digital Piano first.**
- **Formatting a USB flash drive will delete all data on the USB flash drive. Before formatting, make sure that no important data is stored on the USB flash drive.**
- **The format operation performed by this Digital Piano is a “quick format”. To completely delete data, perform a normal format on a computer or other device before formatting on this Digital Piano.**
- **The exFAT format may limit the number of files that can be read if some files have long names.**

1. Insert the USB flash drive to be formatted into the USB Type A port on the Digital Piano.
2. Press and hold the “FUNCTION” button.

Putting in Standby Mode, and Executing on Next Key Press (operation type E)

- Do not release the “FUNCTION” button until step 4.

3. Press the C2 key (Format).

- The right side of the beat indicator blinks and the Digital Piano enters the format standby state.



4. Press the C1 key (Execute).

- Formatting will take place. During formatting, the indicators above the “SOUND MODE” and “▶/■” buttons will light up sequentially, and the Visual Information Bar will indicate that it is in progress (lighting sequentially from the left).

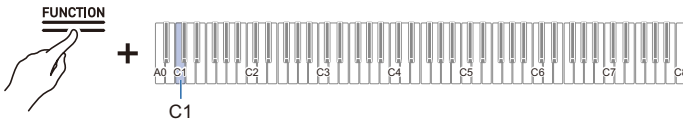

5. Once formatting begins, release the “FUNCTION” button.

- When formatting is complete, the indicators return to their original state.

Operations with a USB Flash Drive

Saving MIDI Recorder Songs to a USB Flash Drive

1. Insert the USB flash drive into the USB Type A port of the Digital Piano.
2. To save in SMF format (.MID), do the following:
 - (1) Switch the Digital Piano to <MIDI Recorder>.

[Switching to MIDI Recorder](#)
 - (2) Select the User Song number that corresponds to the save destination folder (61-70).
While holding down the “▶/■” button, press one of the A0 to F#1 keys.

[Inputting Setting Values Using the Keys 0 to 9 \(operation type C\)](#)
3. Press and hold the “FUNCTION” button.

[Putting in Standby Mode, and Executing on Next Key Press \(operation type E\)](#)

 - Do not release the “FUNCTION” button until step 5.
4. Press either the A1 or B♭1 key.
 - The Hall Simulator/Reverb Indicator blinks and enters save standby.

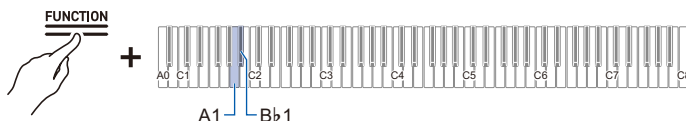

Key	Setting	Storage Location
A1	Saves in SMF format (.MID)	Specified folder in MUSICLIB folder (61-70)
B♭1	Saves in CASIO's proprietary format (.MRF)	MIDIREC Folder

5. Press the C1 key (Execute).

- Save is executed. During processing, the indicators above the “SOUND MODE” and “▶/■” buttons light up sequentially, and the Visual Information Bar will indicate that it is in progress (lighting sequentially from the left).



6. Once saving begins, release the “FUNCTION” button.

- When saving is complete, the indicators return to their original state.

Loading a MIDI File from a USB Flash Drive into the Digital Piano

1. Copy the data to be loaded onto the Digital Piano to the respective folders on the USB flash drive.

- Only one song from each folder can be loaded. When there are multiple files, the first file in the order of the file naming is loaded.

Data Type	Folder
User songs (CMF, MID)	61-70 in MUSICLIB folder
MIDI Recorder songs (MRF)	MIDIREC Folder

2. Insert the USB flash drive into the USB Type A port of the Digital Piano.

3. Switch the Digital Piano to <MIDI Recorder>.

[Switching to MIDI Recorder](#)

4. Select the User Song (song numbers 61-70) or MIDI Recorder Song that corresponds to the data to be loaded.

- To select a User Song, hold down the “▶/■” button and press one of the A0 to F#1 keys.
[Inputting Setting Values Using the Keys 0 to 9 \(operation type C\)](#)
- To select a MIDI Recorder song, hold down the “▶/■” button and press the A2 key.
[Selecting a Setting Value Directly \(operation type A\)](#)

5. Press and hold the “FUNCTION” button.

Putting in Standby Mode, and Executing on Next Key Press (operation type E)

- Do not release the “FUNCTION” button until step 7.

6. Press the Ab 1 key (Load SMF/MRF).

- The surround indicator will blink and enter load standby mode.

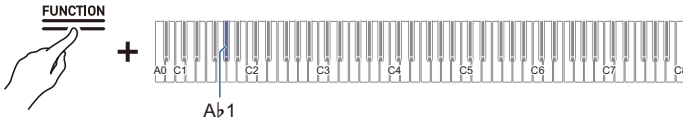

7. Press the C1 key (Execute).

- Loading is executed. During processing, the indicators above the “SOUND MODE” and “▶/■” buttons light up sequentially, and the Visual Information Bar will indicate that it is in progress (lighting sequentially from the left).

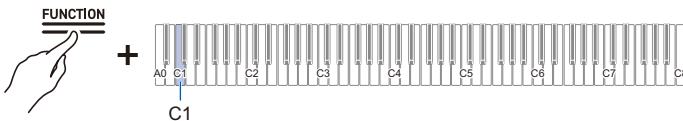

8. Once loading begins, release the “FUNCTION” button.

- When loading is complete, the indicators return to their original state.

Deleting MIDI or Audio Files from a USB Flash Drive

Deletes the following data from the USB flash drive.

- Songs stored in folders 61 to 70 in the MUSICLIB folder
- RECSONG.MRF stored in the MIDIREC folder
- TAKE**.WAV (**=01 - 99) or TAKE**.MP3 (where ** = 01 - 99) audio song data stored in the AUDIOREC folder

1. Insert the USB flash drive into the USB Type A port of the Digital Piano.

2. Select the data to be deleted.

- To delete a User Song or MIDI Recorder Song:

(1) Switch the Digital Piano to <MIDI Recorder>.

[Switching to MIDI Recorder](#)

(2) Select the User Song number or MIDI Recorder Song that corresponds to the data to be deleted.

To select a User Song, hold down the “▶/■” button and press one of the A0 to F#1 keys.

[Inputting Setting Values Using the Keys 0 to 9 \(operation type C\)](#)

To select a MIDI Recorder song, hold down the “▶/■” button and press the A2 key.

[Selecting a Setting Value Directly \(operation type A\)](#)

- To delete audio data:

(1) Switch the Digital Piano to <Audio Recorder (USB Flash Drive)>.

[Switching to Audio Recorder](#)

(2) Specify the TAKE**.WAV or TAKE**.MP3 (where ** = 01 - 99) audio data to delete.

While holding down the “▶/■” button, press one of the A0 to F#1 keys.

[Inputting Setting Values Using the Keys 0 to 9 \(operation type C\)](#)

3. Press and hold the “FUNCTION” button.

[Putting in Standby Mode, and Executing on Next Key Press \(operation type E\)](#)

- Do not release the “FUNCTION” button until step 5.

4. Press the B1 key (Delete SMF/MRF/Audio).

- The left side of the beat indicator blinks and enters the delete standby state.

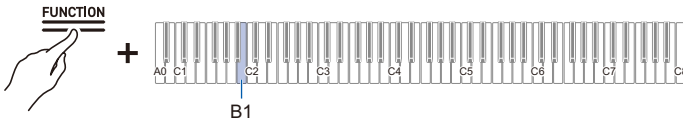

5. Press the C1 key (Execute).

- Deletion will take place. During processing, the indicators above the "SOUND MODE" and "▶/■" buttons light up sequentially, and the Visual Information Bar will indicate that it is in progress (lighting sequentially from the left).

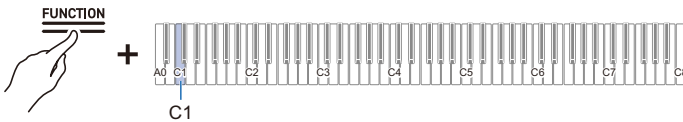

6. Once deletion begins release the "FUNCTION" button.

- When the deletion is complete, the indicators return to their original state.

NOTE

- If there are WAV and MP3 files with the same name, executing file deletion will delete both the WAV and the MP3 files.

Save a Batch of Audio Files from the Internal Memory to a USB Flash Drive

Audio files (Audio Recorder songs and general audio files) stored in the internal memory of the Digital Piano can be saved to a USB flash drive in a batch using the following operation.

1. Insert the USB flash drive into the USB Type A port of the Digital Piano.
2. While holding down the “FUNCTION” button, press the F#1 key (Save All Audio).

Putting in Standby Mode, and Executing on Next Key Press (operation type E)

- The Visual Information Bar will blink except at both ends, and the Digital Piano will enter a standby state for saving. The Hall Simulator/Reverb Indicator also blinks.
- Do not release the “FUNCTION” button until step 3.

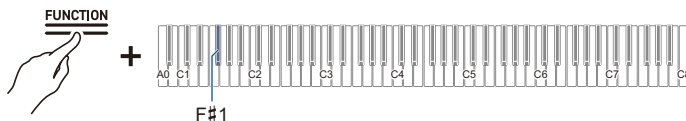

3. While holding down the “FUNCTION” button, press the C1 key (Execute).

- Saving will take place. During processing, the indicators above the “SOUND MODE” and “▶■” buttons light up sequentially, and the Visual Information Bar will indicate that it is in progress (lighting sequentially from the left).

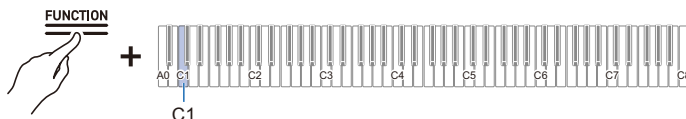

4. Once saving begins, release the “FUNCTION” button.

- When saving is complete, the indicators return to their original state.

NOTE

- If an audio file of the same name (“TAKE**.WAV” or “TAKE**.MP3” (where ** = 01 - 99)) already exists in the AUDIOREC folder on the USB flash drive, the file will be overwritten by the “TAKE**.WAV” or “TAKE**.MP3” file.

Loading Audio Files from a USB Flash Drive onto the Digital Piano in Batches

Audio files (Audio Recorder songs and general audio files) stored on a USB flash drive can be loaded into the internal memory of the Digital Piano in a batch using the following operation.

1. Prepare a USB flash drive containing the audio files you wish to load into the Digital Piano.

- Audio files (“TAKE** .WAV” (where ** = 01 - 99)) or “TAKE** .MP3” (where ** = 01 - 99)) stored in the AUDIOREC folder on the USB flash drive are eligible for loading. If there are WAV and MP3 files of the same name in the folder, the WAV file will be loaded.

2. Insert the USB flash drive into the USB Type A port of the Digital Piano.

3. While holding down the “FUNCTION” button, press the G1 key (Load All Audio).

Putting in Standby Mode, and Executing on Next Key Press (operation type E)

- The Visual Information Bar displays the approximate amount of free space in the internal memory, and the Digital Piano enters a standby state for loading.
- Do not release the “FUNCTION” button until step 4.

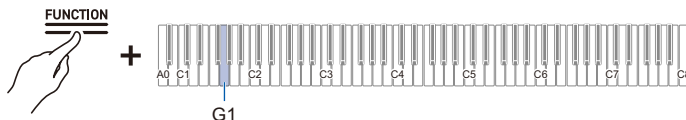

4. While holding down the “FUNCTION” button, press the C1 key (Execute).

- Loading will take place. During processing, the indicators above the “SOUND MODE” and “▶/■” buttons light up sequentially, and the Visual Information Bar will indicate that it is in progress (lighting sequentially from the left).

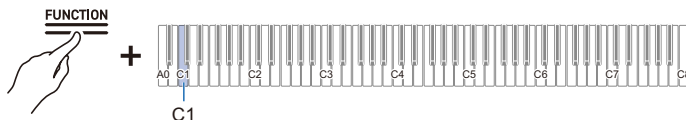

5. Once loading begins, release the “FUNCTION” button.

- When loading is complete, the indicators return to their original state.

NOTE

- If you want to overwrite a specific song in the internal memory, confirm the number of the song you want to overwrite in advance by “[Selecting a Song for Playback](#)”. If you save an audio file with that song number in the AUDIOREC folder on the USB flash drive, only the songs with the corresponding song number in the internal memory will be overwritten.

For example, if you want to overwrite song number 15 in the internal memory, save “TAKE15.WAV” or “TAKE15.MP3” in the AUDIOREC folder of the USB flash drive.

Saving User Scenes to a USB Flash Drive

User scenes stored in the Digital Piano (all user scenes 1 through 10) can be saved to a USB flash drive as follows.

1. Insert the USB flash drive into the USB Type A port of the Digital Piano.
2. While holding down the “SCENE” button, press the Ab7 key (Save).

Putting in Standby Mode, and Executing on Next Key Press (operation type E)

- The Hall Simulator/Reverb Indicator blinks and the Digital Piano enters save standby.
- Do not release the “SCENE” button until the next operation is completed.

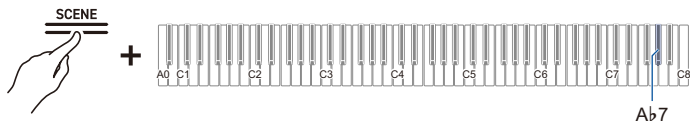

3. While holding down the “SCENE” button, press the C8 key (Execute).

- Saving will take place.
- A user scene file (SCENE.SCS) is saved in the SCENE folder of the USB flash drive.

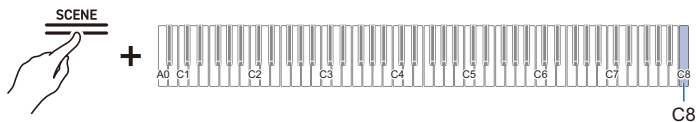

Loading a User Scene File Saved on a USB Flash Drive onto this Digital Piano

The following operation will overwrite all user scenes on the Digital Piano with the contents of the user scene file on the USB flash drive.

1. Insert the USB flash drive containing the user scene file into the USB Type A port on the Digital Piano.

- The user scene file (SCENE.SCS) stored in the SCENE folder of the USB flash drive is the target for loading.

2. While holding down the “SCENE” button, press the A7 key (Load).

Putting in Standby Mode, and Executing on Next Key Press (operation type E)

- The surround indicator will blink and enter load standby mode.
- Do not release the “SCENE” button until the next operation is complete.

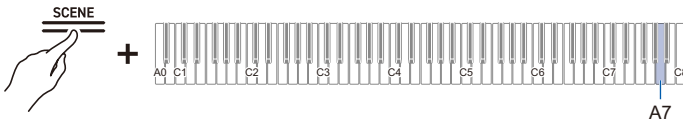

3. While holding down the “SCENE” button, press the C8 key (Execute).

- Loading will take place.

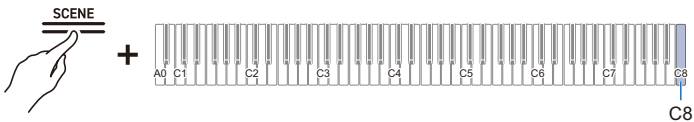

Delete user scene files on a USB flash drive

1. Insert the USB flash drive containing the user scene file into the USB Type A port on the Digital Piano.

2. While holding down the “SCENE” button, press the B \flat 7 key (Delete).

Putting in Standby Mode, and Executing on Next Key Press (operation type E)

- The left side of the beat indicator will blink, indicating that the Digital Piano is waiting for you to delete the file.
- Do not release the “SCENE” button until the next operation is completed.

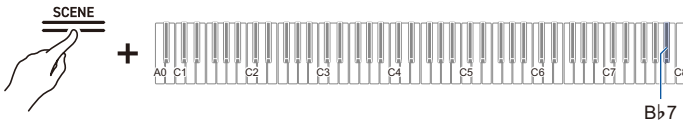

3. While holding down the “SCENE” button, press the C8 key (Execute).

- Deletion will take place.

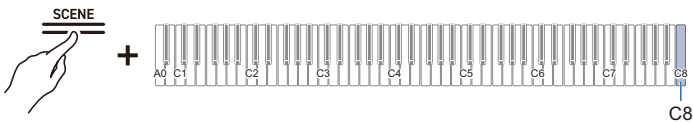

Copying MIDI Song Data to a USB Flash Drive Using a Computer

You can save files in the following formats to the MUSICLIB folder in the CASIO folder created on a USB flash drive and play them on this Digital Piano.

- Standard MIDI file (SMF format 0/1) or CASIO MIDI file (CMF format)

- 1. Connect the USB flash drive to the computer.**
- 2. Create a CASIO folder in the root directory of the USB flash drive and create a folder named MUSICLIB in the CASIO folder.**
 - If you already have a MUSICLIB folder, this step is not necessary.
- 3. Copy the song data you want to play on the Digital Piano to the MUSICLIB folder on the USB flash drive.**
 - For song data playback, see [“Playing MIDI Data”](#).

Copying Audio Data (WAV, MP3) to a USB Flash Drive Using a Computer

When you record with this Digital Piano's Audio Recorder (USB Drv.), the recordings are stored in WAV file format under the AUDIOREC folder in the CASIO folder on the USB flash drive from “TAKE01.WAV” to “TAKE99.WAV”, with a new number being assigned to the new file each time a recording is made.

Connect the USB flash drive to a computer, change audio data file (WAV or MP3 file) names to “TAKE**.WAV” (where ** = 01 - 99) or MP3 file names to “TAKE**.MP3” (where ** = 01 - 99) and save in the AUDIOREC folder to play the files on this Digital Piano.

- WAV files (Linear PCM, 16 bit, 44.1 kHz, stereo, extension: .WAV)
- MP3 files (MPEG-1 Audio Layer 3, 44.1 kHz/48 kHz, bit rate 32-320 kbps/variable bit rate (VBR) compatible, mono/stereo, extension: .MP3)

For information on audio data playback, see [“Playing Audio Data \(WAV, MP3\)”](#).

Connecting Wirelessly

Connecting the Digital Piano to External Devices Wirelessly

The supplied Wireless MIDI & audio adaptor can be used to connect the Digital Piano to external devices wirelessly. This connection uses Bluetooth wireless technology, and the following two types of connections are possible:

- Bluetooth Low Energy MIDI Connectivity
Sends and receives MIDI data between the Digital Piano and smart devices.
- Bluetooth audio connectivity
Plays the sound being played back from an external device on this Digital Piano.

Wireless (Bluetooth) Connectivity Settings

Wireless Function On/Off

The [Wireless Function] of the Digital Piano is set to <On> by default. When necessary, such as when you want to stop the generation of radio waves, you can turn the [Wireless Function] <Off>.

1. Insert the Wireless MIDI & audio adaptor into the USB Type A port on the Digital Piano.
2. While holding down the “FUNCTION” button, press the D1 key (Wireless Function).

Switching On/Off or Changing Setting Values Using a Single Key (operation type D)

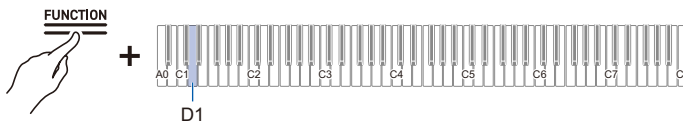

- Default value: On

Setting Value	Setting Details
Off	Turns off the Wireless Function.
On	Turns on the Wireless Function.

Adjusting the Notification Tone Volume for Wireless Connection/Disconnection

You can adjust the Notification Tone Volume that sounds when the wireless connection status changes.

Notification Tones

Notification Details	Notification Tone
Connected to Bluetooth audio-enabled device	A piano tone with an ascending melody plays.
Disconnected from a Bluetooth audio-enabled device	A piano tone with a descending melody plays.
Connected to a Bluetooth Low Energy MIDI-enabled device	A vibraphone tone with an ascending melody plays.
Disconnected from a Bluetooth Low Energy MIDI-enabled device	A vibraphone tone with a descending melody plays.

Adjusting the Notification Tone Volume

While holding down the “FUNCTION” button, press the E \flat 1 or E1 key.

Using the +/- Keys to Raise or Lower the Setting Value by 1 (operation type B)

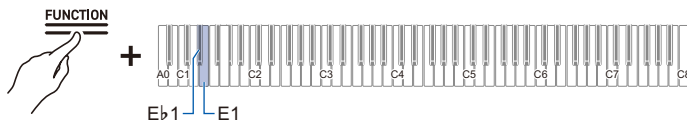

- Setting value: 0 (silence) to 10 (maximum volume)
- Default value: 5

Key	Setting
E \flat 1	Lowers the volume of the connection notification tone by 1 (–)
E1	Raises the volume of the connection notification tone by 1 (+)
E \flat 1 + E1	Resets the volume of the connection notification tone to its default setting

Bluetooth Low Energy MIDI Connectivity

Bluetooth Low Energy MIDI connection between the Digital Piano and a smart device enables various operations using a dedicated app. To connect with Bluetooth Low Energy MIDI, you need to install the dedicated app on your smart device.

For more information about the dedicated app, see “[Downloading the App \(CASIO MUSIC SPACE\) for Smart Devices](#)”.

- 1. If the [Wireless Function] of the Digital Piano is <Off>, switch it to <On>.**
 - For more information, see “[Wireless Function On/Off](#)”.
- 2. Connect the Wireless MIDI & audio adaptor to the USB Type A port on the Digital Piano.**
- 3. Open the settings screen of the smart device and check the Bluetooth function is on.**
- 4. On the settings screen of the dedicated app installed on the smart device, select “WU-BT10 MIDI” and connect it to this Digital Piano.**
 - For details, see the dedicated app instruction manual.
 - Do not operate the Digital Piano while it is waiting to connect to a smart device.
 - When connected, the left side of the “ (Power)” button lights up blue.

NOTE

- Each time the dedicated app is used with a Bluetooth Low Energy MIDI connection, the operation described in step 4 above is required.
- Connecting this Digital Piano to Bluetooth Low Energy MIDI and Bluetooth audio from an external device at the same time may result in unstable MIDI operation depending on the external device and OS version. If this happens, disconnect the Bluetooth audio connection using the external device.

Bluetooth Audio Connectivity

Using the supplied Wireless MIDI & audio adaptor, you can pair the Digital Piano with a Bluetooth audio-enabled device (smart device) to play sound from an external device through the Digital Piano's speakers.

! IMPORTANT!

- When pairing, keep the volume of the Digital Piano and the external device turned down to a low level.
- If the sound of an external device played by the Digital Piano sounds distorted, turn down the volume of the external device.
- Due to the characteristics of Bluetooth, sound is delayed.

Bluetooth Audio Pairing

1. Connect the Wireless MIDI & audio adaptor to the USB Type A port on the Digital Piano.

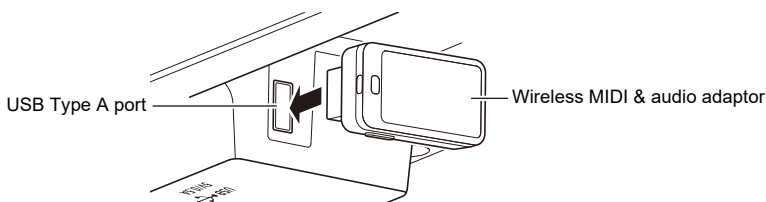

2. Open the settings screen of the external device and switch the Bluetooth function to on if it is off.
3. While holding down the “FUNCTION” button on the Digital Piano, press the C#1 key (Wireless Audio Pairing).

[Selecting a Setting Value Directly \(operation type A\)](#)

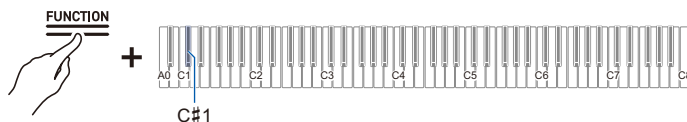

- The device enters pairing standby.
 - The Visual Information Bar shows two bars moving left and right to indicate that the device is standing by for pairing.
4. Select “WU-BT10 AUDIO” on the Bluetooth settings screen of the external device and pair it with this Digital Piano.
 - When connected, a notification tone will sound and the right side of the “⏻ (Power)” button will light up blue.

■ If the Bluetooth Audio Connection Does Not Work Properly**1. Clear pairing registration.**

- For more information, see [“Clearing Pairing Registration”](#).

2. If pairing registration information from this Digital Piano remains on the external device, delete it.

- Delete “WU-BT10 AUDIO” from the Bluetooth settings screen of the external device. For how to do this, see the external device’s instruction manual.

3. Retry Bluetooth audio pairing.

- For more information, see [“Bluetooth Audio Pairing”](#).

 **NOTE**

- The pairing information of the last external device connected via Bluetooth audio is registered in the Wireless MIDI & audio adaptor. From then on, a Bluetooth audio connection is automatically established without the need for Bluetooth audio pairing.

Clearing Pairing Registration

Delete pairing registrations between the Digital Piano and external devices connected via Bluetooth audio.

NOTE

- After executing the following operation, delete pairing registration information with this Digital Piano, even for external devices that were connected to this Digital Piano via Bluetooth audio. Delete “WU-BT10 AUDIO” from the Bluetooth settings screen of the external device. For how to do this, see the external device’s instruction manual.

- 1. Connect the Wireless MIDI & audio adaptor to the USB Type A port on the Digital Piano.**
- 2. Press and hold the “FUNCTION” button.**
Putting in Standby Mode, and Executing on Next Key Press (operation type E)
 - Do not release the “FUNCTION” button until step 4.
- 3. Press the F1 key (Delete Connection History).**

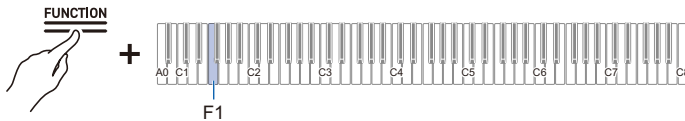

- 4. Press the C1 key (Execute) to clear pairing registrations.**
- 5. Release the “FUNCTION” button.**

Adjusting Wireless Audio Playback Volume

While holding down the “FUNCTION” button, press the B2 or C3 key.

Using the +/- Keys to Raise or Lower the Setting Value by 1 (operation type B)

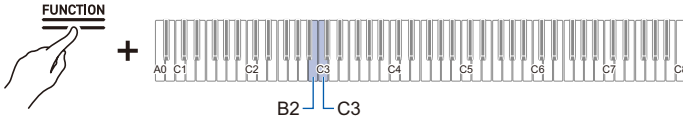

- Setting value: 0 (silence) to 42 (maximum volume)
A separator tone sounds when the set value becomes a multiple of 10.
- Default value: 35

Key	Setting
B2	Lowers wireless audio playback volume by 1 (-)
C3	Raises wireless audio playback volume by 1 (+)
B2 + C3	Resets wireless audio playback volume to default setting

Using the Dedicated App

Downloading the App (CASIO MUSIC SPACE) for Smart Devices

When using the dedicated CASIO MUSIC SPACE app, you can enjoy numerous features linked to this Digital Piano.

Main App Features

- Piano Remote Controller
- Piano Roll
- Music Player

See the CASIO MUSIC SPACE instruction manual for details on each function and other features.

https://web.casio.com/app/en/music_space/manual/

1. Installing CASIO MUSIC SPACE on Your Smart Device

- See “Downloads” at the following website.
<https://support.casio.com/global/en/emi/manual/AP-750/>



2. Connecting this Digital Piano to a Smart Device

- There are two types of connections: wireless and cable. Available features vary depending on the connection method.
- Do not make Bluetooth Low Energy MIDI connections and USB MIDI connections at the same time.

Main App Features	Wireless Connection		Cable Connection
	Bluetooth Low Energy MIDI Connection ^{*2}	Bluetooth Audio Connection ^{*3}	USB MIDI Connection ^{*4}
Piano Remote Controller	✓	–	–
Piano Roll ^{*1}	✓	–	–
Music Player	–	✓	–

CASIO MUSIC SPACE website

https://web.casio.com/app/en/music_space/

*1 User Songs can be transferred to this Digital Piano using this function.

*2 See [Bluetooth Low Energy MIDI Connectivity](#)

*3 See [Bluetooth Audio Connectivity](#)

*4 See [Connecting a Smart Device with USB MIDI](#)

Using with an External Device with a Cable Connection

Connecting to a Computer or Smart Device and Using MIDI

You can send and receive performance information (MIDI data) by connecting this Digital Piano to a computer or smart device. You can use music software on your computer or a smart device application to record your performance on this Digital Piano, or send data from your computer or smart device to this Digital Piano and play the sound.

NOTE

- For detailed specifications and connection information on sending and receiving MIDI data with this Digital Piano, see "[Latest Support Information](#)".
- For MIDI-related settings, see "[Changing MIDI Settings](#)".

Computer Operating Environment

The operating environment required to send and receive MIDI data is as follows: Always confirm the environment of your computer in advance.

- USB port
- Supported OS
 - Windows 10*
 - Windows 11
 - macOS 11,12,13,14,15

* Windows 10 (32-bit and 64-bit versions)

NOTE

- For the latest information on supported OS, see "[Latest Support Information](#)".

Connecting to a Computer

IMPORTANT!

- Failure to connect using the correct procedure may result in the inability to send and receive data. Always follow the steps below to make a connection.
- After connecting, always turn on the Digital Piano before starting up music software on your computer.

1. Turn off the power to the Digital Piano and start up the computer.
 - Do not start up any music software on your computer.
2. Connect the computer and the Digital Piano using the USB Type B port of the Digital Piano with a commercially available USB cable.
 - Use a cable with USB Type B (USB 1.1 or 2.0) connector.

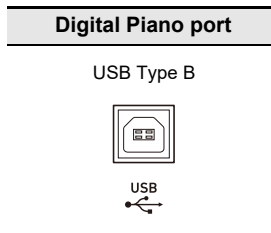

3. Turn on the Digital Piano's power.
 - When connecting for the first time, the driver required to send and receive data is automatically installed on the computer.
4. Start the music software (commercially available) on your computer.
5. In the settings of your computer's music software (commercially available), select MIDI Device.
 - The device name is "CASIO AP-750 USB".
 - See the manual of your music software for information on how to select a MIDI device.

NOTE

- After one successful connection, the USB cable can be left connected and the computer or this Digital Piano can be turned on and off.

Smart Device Operating Environment

You can connect to smart devices and use apps that use MIDI standards.

See “[Latest Support Information](#)” for confirmed compatible devices.

- We recommend using the devices listed in the “Tested devices (USB-MIDI connection)” section.
- Operation confirmation results do not guarantee operation on that device.
- Depending on your environment, you may not be able to connect correctly.
- Even if the device has been tested, it may not work properly due to device or OS version upgrades, etc.

Connecting a Smart Device with USB MIDI

- Use a cable that supports data communication.
- Charging cables are not compatible.

- 1. Turn on the Digital Piano and the smart device.**
- 2. Use a cable to connect the smart device to the USB Type B port of the Digital Piano.**
 - For connection cables, see “Connecting via USB Cable” at the website below.
https://web.casio.com/app/en/music_space/support/connect.html
- 3. Launch the MIDI-compatible app on your smart device.**
 - When using CASIO’s dedicated app, if a successful connection is made, the message “Connecting” will appear on the smart device screen, followed by the message “Connected”.

Outputting the Digital Piano's Sound to an Amplifier or Audio Equipment

When connected to an audio device or an amplifier for musical instruments, you can enjoy performances with more powerful volume and sound quality in line with the speaker capabilities of those devices. To make a connection, use a commercially available connection cord.

IMPORTANT!

- Turn off all external devices when connecting. Also, keep the volume settings of the Digital Piano and external devices turned down to minimum when turning the power On/Off.
- After connecting, turn on the power to the Digital Piano and the external device, in that order.
- If the sound of this Digital Piano played by an external device sounds distorted, turn down the volume of the Digital Piano.
- Set [Headphone Mode] to <Off> when connecting to an amplifier or other audio equipment.

Connecting to Audio Equipment

LINE OUT R (Right) is the right channel sound and LINE OUT L/MONO (Left) is the left channel sound. Connect both as shown in the figure with a commercially available connection cord. You will most likely need to switch the input selector of your audio device to the connected terminal (AUX IN etc.).

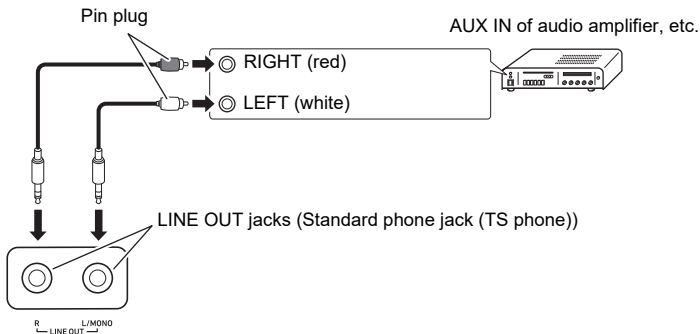

Connecting to a Musical Instrument Amplifier

If you connect only to LINE OUT L/MONO, you will get a mixture of both channels. Use a commercially available connection cord and make a connection as shown in the diagram.

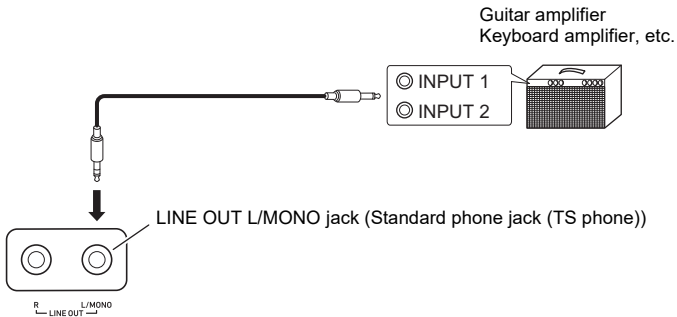

Changing Settings

Changing the Upper1 Part Settings

Adjusting the Upper1 Part Volume

While holding down the “TONE” button, press the A0 or B♭0 key.

Using the +/- Keys to Raise or Lower the Setting Value by 1 (operation type B)

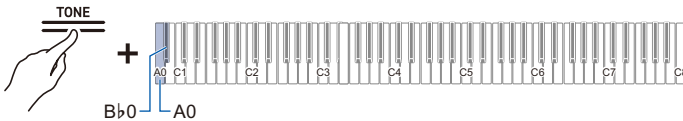

- Setting value: 0 (silence) to 42 (maximum volume)
A separator tone sounds when the set value becomes a multiple of 10.
- Default value: 42

Key	Setting
A0	Lowers the volume of the Upper1 part by one level (-)
B♭0	Increases the volume of the Upper1 part by one level (+)
A0 + B♭0	Resets the volume of the Upper1 part to the default setting

Changing the Upper2 Part Settings

Adjusting the Upper2 Part Volume

While holding down the “TONE” button, press the C#7 or D7 key.

Using the +/- Keys to Raise or Lower the Setting Value by 1 (operation type B)

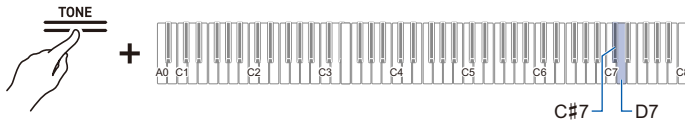

- Setting value: 0 (silence) to 42 (maximum volume)
A separator tone sounds when the set value becomes a multiple of 10.
- Default value: 26

Key	Setting
C#7	Lowers the volume of the Upper2 part by one level (-)
D7	Increases the volume of the Upper2 part by one level (+)
C#7 + D7	Resets the volume of the Upper2 part to the default setting

Fine-Tuning the Upper2 Part (Upper2 Detune)

Fine-tune the relative pitch of the Upper2 part to the Upper1 part.

While holding down the “TONE” button, press the F7 or F#7 key.

Using the +/- Keys to Raise or Lower the Setting Value by 1 (operation type B)



- Setting value: -99 cents to +99 cents (100 cents = 1 semitone)
A separator tone sounds when the set value becomes a multiple of 10.
- Default value: 0 cents

Key	Setting
F7	Lowers the pitch of the Upper2 part by 1 cent (-)
F#7	Raises the pitch of the Upper2 part by 1 cent (+)
F7 + F#7	Sets the pitch of the Upper2 part to the same as the Upper1 part (default setting)

Enabling/Disabling Upper2 Part Damper Pedal Effect

Sets whether the Damper Pedal Effect is applied or not to the Upper2 part.

While holding down the “TONE” button, press the G7 key (Upper2 Damper).

[Switching On/Off or Changing Setting Values Using a Single Key \(operation type D\)](#)

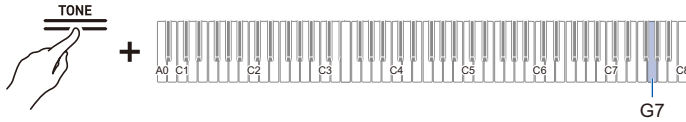

- Default value: Enabled

Setting Value	Setting Details
Disabled	Disables the Damper Pedal Effect.
Enabled	Enables the Damper Pedal Effect.

Changing the Lower Part Settings

Adjusting the Lower Part Volume

While holding down the “TONE” button, press the **A \flat 7** or **A7** key.

Using the +/- Keys to Raise or Lower the Setting Value by 1 (operation type B)



- Setting value: 0 (silence) to 42 (maximum volume)
A separator tone sounds when the set value becomes a multiple of 10.
- Default value: 42

Key	Setting
A \flat 7	Decreases Lower part volume by 1 level (-)
A7	Increases the volume of the Lower part by one level (+)
A \flat 7 + A7	Resets the volume of the Lower part to the default setting

Fine-Tuning the Lower Part (Lower Detune)

Fine-tune the relative pitch of the Lower part to the Upper1 part.

While holding down the “TONE” button, press the **B \flat 7** or **B7** key.

Using the +/- Keys to Raise or Lower the Setting Value by 1 (operation type B)



- Setting value: -99 cents to +99 cents (100 cents = 1 semitone)
A separator tone sounds when the set value becomes a multiple of 10.
- Default value: 0 cents

Key	Setting
B \flat 7	Decreases Lower part pitch by 1 cent (-)
B7	Increases Lower part pitch by 1 cent (+)
B \flat 7 + B7	Sets the pitch of the Lower part to the same as the Upper1 part (default setting)

Enabling/Disabling Lower Part Damper Pedal Effect

Sets whether the Damper Pedal Effect is applied or not to the Lower part.

While holding down the “TONE” button, press the C8 key (Lower Damper).

[Switching On/Off or Changing Setting Values Using a Single Key \(operation type D\)](#)



- Default value: Disabled

Setting Value	Setting Details
Disabled	Disables the Damper Pedal Effect.
Enabled	Enables the Damper Pedal Effect.

Saving the Digital Piano Settings (Auto Resume)

When [Auto Resume] is set to <On>, most settings are retained, even when the Digital Piano is turned off.

- The settings that are retained regardless of whether [Auto Resume] is set to <Enabled> or <Disabled> are as follows:

The A Tuning setting, piano position, half pedal position, Visual Information Bar brightness/off setting, wireless connection notification sound volume, touch button setting, notification sound setting and auto-resume setting

While holding down the “FUNCTION” button, press the A \flat 7 key (Auto Resume).

Switching On/Off or Changing Setting Values Using a Single Key (operation type D)

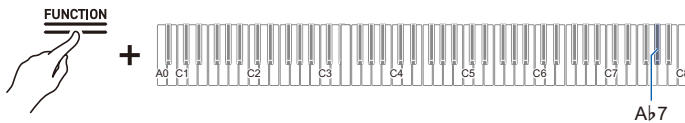

- Default value: Disabled

Setting Value	Setting Details
Disabled	Disables Auto Resume.
Enabled	Enables Auto Resume.

Restore Factory Defaults (Factory Reset)

You can initialize all system content on this Digital Piano, such as data and settings, and return the Digital Piano to the settings it had when it was shipped from the factory.

1. Press and hold the “FUNCTION” button.

Putting in Standby Mode, and Executing on Next Key Press (operation type E)

2. Press the A0 key (Factory Reset).

- The Digital Piano enters factory reset standby and the “FUNCTION” button blinks.
- Perform factory reset in the following way. To stop factory reset, release the “FUNCTION” button at this point.

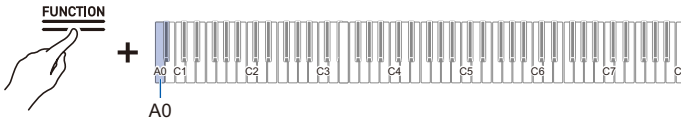

3. To execute factory reset, press the C1 key (Execute).

- Factory reset starts.

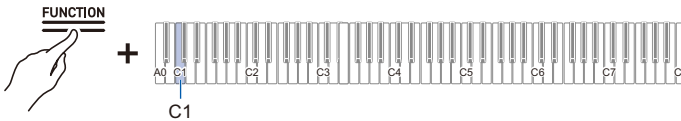

4. Release the “FUNCTION” button.

- Factory reset may take some time. Wait until the process is complete. When factory reset is complete, all touch buttons on the Digital Piano (FUNCTION to TONE, BERLIN GRAND to METRONOME) will light up.

Adjusting Volume Balance

You can adjust the volume of keyboard performances, MIDI song playback, audio song playback, and wireless audio playback individually, relative to the overall volume.

Keyboard Volume

While holding down the “FUNCTION” button, press the G3 or A♭3 key.

Using the +/- Keys to Raise or Lower the Setting Value by 1 (operation type B)

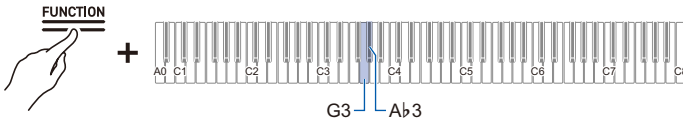

- Setting value: 0 (silence) to 42 (maximum volume)
A separator tone sounds when the set value becomes a multiple of 10.
- Default value: 42

Key	Setting
G3	Lowers Keyboard Volume by 1 (-)
A♭3	Raises Keyboard Volume by 1 (+)
G3 + A♭3	Resets Keyboard Volume to default setting

MIDI Song Volume

Adjusts the playback volume of built-in songs, user songs, MIDI Recorder songs, and USB flash drive songs.

While holding down the “FUNCTION” button, press the F3 or F#3 key.

Using the +/- Keys to Raise or Lower the Setting Value by 1 (operation type B)

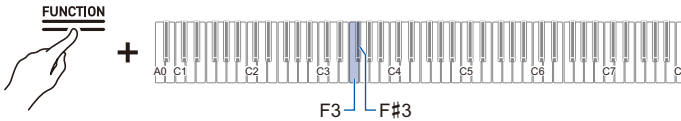

- Setting value: 0 (silence) to 42 (maximum volume)
A separator tone sounds when the set value becomes a multiple of 10.
- Default value: 42

Key	Setting
F3	Lowers the playback volume of MIDI songs by 1 (-)
F#3	Raises the playback volume of MIDI songs by 1 (+)
F3 + F#3	Resets the playback volume of MIDI songs to the default setting

Audio Song Playback Volume

Adjusts the playback volume of audio data (WAV and MP3 files).

While holding down the “FUNCTION” button, press the D3 or E♭3 key.

Using the +/- Keys to Raise or Lower the Setting Value by 1 (operation type B)

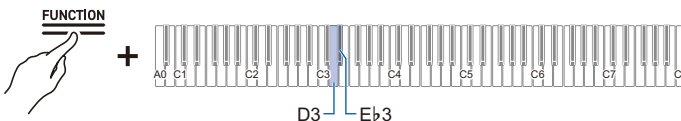

- Setting value: 0 (silence) to 42 (maximum volume)
A separator tone sounds when the set value becomes a multiple of 10.
- Default value: 35

Key	Setting
D3	Lowers the playback volume of an audio song by 1 (-)
E♭3	Raises the playback volume of audio songs by 1 (+)
D3 + E♭3	Resets the playback volume of audio songs to the default setting

Wireless Audio Playback Volume

Adjusts the playback volume of wireless audio.

While holding down the “FUNCTION” button, press the B2 or C3 key.

Using the +/- Keys to Raise or Lower the Setting Value by 1 (operation type B)

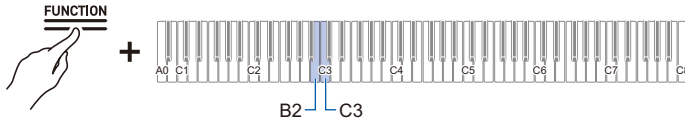

- Setting value: 0 (silence) to 42 (maximum volume)
A separator tone sounds when the set value becomes a multiple of 10.
- Default value: 35

Key	Setting
B2	Lowers wireless audio playback volume by 1 (-)
C3	Raises wireless audio playback volume by 1 (+)
B2 + C3	Resets wireless audio playback volume to default setting

Center Cancel Function

When [Center Cancel] is set to <On>, the vocals are cut from playback (cut or lowered). This function cancels centrally positioned sounds, so sounds other than vocals may also be cut. The degree of the effect depends on the audio data being played.

While holding down the “FUNCTION” button, press the C#3 or E3 key.

Switching On/Off or Changing Setting Values Using a Single Key (operation type D)

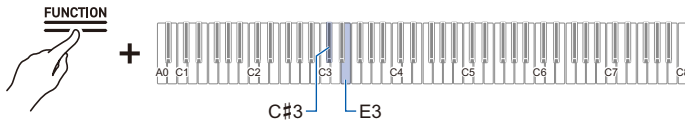

Wireless Audio Center Cancel (C#3 key)

- Default value: Off

Setting Value	Setting Details
Off	Turns off Wireless Audio Center Cancel.
On	Turns on Wireless Audio Center Cancel. Cancels the center-positioned sound of wireless audio.

Audio Song Center Cancel (E3 key)

- Default value: Off

Setting Value	Setting Details
Off	Turns off Audio Song Center Cancel.
On	Turns on Audio Song Center Cancel. Cancels the center-positioned sound of an audio song.

Changing MIDI Settings

Local Control

When [Local Control] is set to <Off>, MIDI data is output from this Digital Piano, but the Digital Piano itself does not emit sound. This setting is for sending MIDI data to external devices only.

While holding down the “FUNCTION” button, press the F6 key (Local Control).

Switching On/Off or Changing Setting Values Using a Single Key (operation type D)



- Default value: On

Setting Value	Setting Details
Off	Turns off Local Control.
On	Turns on Local Control.

Keyboard Channel

Sets the MIDI channel to be used when sending keyboard performance information from this Digital Piano to an external device.

While holding down the “FUNCTION” button, press the F#6 or G6 key.

Using the +/- Keys to Raise or Lower the Setting Value by 1 (operation type B)

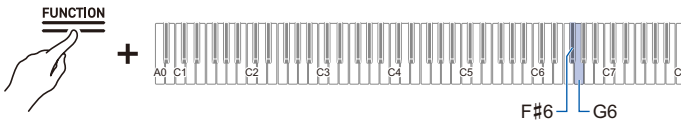

- Setting value: 1ch to 16ch
- Default value: 1ch

Key	Setting
F#6	Lowers the Keyboard Channel by 1 (-)
G6	Raises the Keyboard Channel by 1 (+)
F#6 + G6	Resets the Keyboard Channel to the default setting

Hi-Res Velocity MIDI OUT

Set high-resolution MIDI output for touch strength (Velocity) to <Enable> or <Disable> when playing the keyboard.

While holding down the “FUNCTION” button, press the A_b6 key (Hi-Res Velocity MIDI OUT).

Switching On/Off or Changing Setting Values Using a Single Key (operation type D)

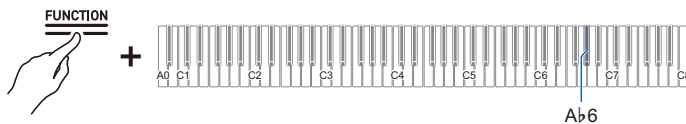

- Default value: Disabled

Setting Value	Setting Details
Disabled	Disables Hi-Res Velocity MIDI OUT.
Enabled	Enables Hi-Res Velocity MIDI OUT.

Setting the Display of the Visual Information Bar

The Visual Information Bar displays various lighting patterns according to the beat of the metronome, the touch strength (velocity) when playing the keyboard, and the depth to which the damper pedal is pressed.

Changing Display Settings

The lighting pattern of the Visual Information Bar changes depending on the display settings.

While holding down the “FUNCTION” button, press one of the F5 to A5 keys.

Selecting a Setting Value Directly (operation type A)

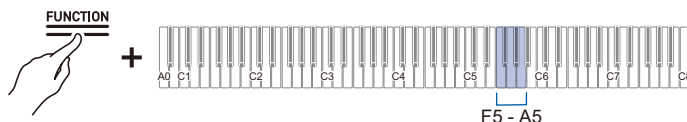

- Default value: Auto
- When the display is set to a setting other than <Auto>, it will light up only when the action or operation of the selected setting is performed.

Key	Display Settings	Setting Details
F5	Auto	The display automatically changes in response to your performance and operations on the Digital Piano.
F#5	Metronome	Lights up to the beat only when the metronome is playing. Lighting patterns can be switched.
G5	Keyboard	Lights up in response to touch strength (velocity) when the keys are played or according to the velocity of the song playing on the Digital Piano.
A♭5	Pedal	Lights up in response to the depth to which the damper pedal is pressed.
A5	Audio	Lights up in response to the wireless audio input signal. Lighting patterns can be switched.

For the following operations, the Visual Information Bar lights up regardless of display settings.

- During demo song playback: Lights up in response to the velocity of the song.
- While making various settings using the keyboard: The set value or approximate value lights up.
- During Instant RePlayer playback: Lights up to indicate where the current playback position is in the overall recording.
- When connected to CASIO MUSIC SPACE and using the “Live Concert Simulator” feature: Lights up in response to audio input from the app.

NOTE

- When the display setting is <Auto>, the Visual Information Bar does not blink in response to a wireless audio input signal. Set the display setting to <Audio>.

■ Switching Lighting Patterns

When the display settings are <Metronome> and <Audio>, you can switch the lighting pattern.

Metronome Type

The Visual Information Bar displays the beat in time with the metronome beat. You can choose from five types of beat display using the [Metronome Type] setting.

While holding down the “FUNCTION” button, press the B \flat 5 key (Metronome Type).

Switching On/Off or Changing Setting Values Using a Single Key (operation type D)

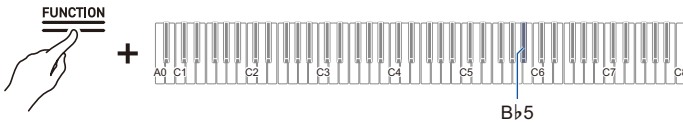

Audio Illumination Type

The Visual Information Bar blinks in time with the wireless audio input signal, allowing you to enjoy the illumination display. The [Audio Illumination Type] setting allows you to select from four types of illumination display.

While holding down the “FUNCTION” button, press the B5 key (Audio Illumination Type).

Switching On/Off or Changing Setting Values Using a Single Key (operation type D)

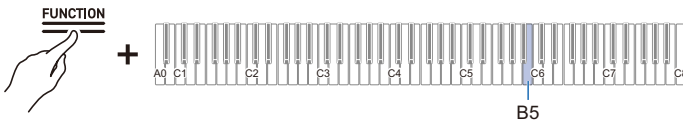

Brightness Setting and No Lighting

If the brightness of the Visual Information Bar is a little too bright, you can reduce the brightness or turn it off.

While holding down the “FUNCTION” button, press the C6 key (Brightness/Off).

Switching On/Off or Changing Setting Values Using a Single Key (operation type D)

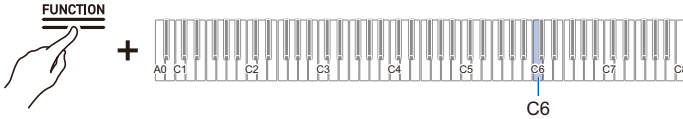

- Default value: 2

Setting Value	Notification Tone	Setting Details
Off	Tone for Off	Turns off the Visual Information Bar.
1	1 notification tone	Displays the Visual Information Bar with reduced brightness.
2	2 notification tones	Displays the Visual Information Bar at normal brightness.

Main Digital Piano Settings

Power On Alert

Set whether [Power On Alert] is <Enabled> or <Disabled>.

For more information, see “[Power On Alert](#)”.

While holding down the “FUNCTION” button, press the F#7 key (Power On Alert).

Switching On/Off or Changing Setting Values Using a Single Key (operation type D)



- Default value: Enabled

Setting Value	Setting Details
Disabled	Disables Power On Alert.
Enabled	Enables Power On Alert.

Auto Power Off

Set whether [Auto Power Off] is <Enabled> or <Disabled>.

For more information, see “[Auto Power Off Function](#)”.

While holding down the “FUNCTION” button, press the B♭0 key (Auto Power Off).

Switching On/Off or Changing Setting Values Using a Single Key (operation type D)



- Default value: Enabled

Setting Value	Setting Details
Disabled	Disables Auto Power Off.
Enabled	Enables Auto Power Off.

⚠ WARNING

If [Auto Power Off] is set to <Disable>, the product does not automatically turn off and continues to use power.

Touch Button Luminosity

While holding down the “FUNCTION” button, press the B \flat 6 key (Touch Button Luminosity).

Switching On/Off or Changing Setting Values Using a Single Key (operation type D)

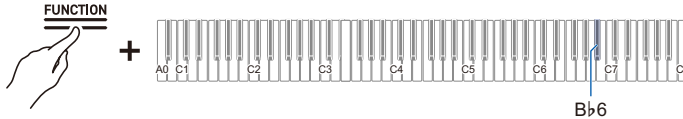

- Default value: 2

Setting Value	Setting Details
1	Dims touch button luminosity.
2	Brightens touch button luminosity.

Left Panel Touch Button Sensitivity

While holding down the “FUNCTION” button, press the B6 or C7 key.

Using the +/- Keys to Raise or Lower the Setting Value by 1 (operation type B)

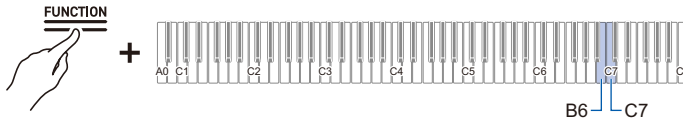

- Setting value: -1 (low sensitivity) to 0 (standard) to +1 (high sensitivity)
- Default value: 0

Key	Setting
B6	Lowers touch button sensitivity by 1 (-)
C7	Raises touch button sensitivity by 1 (+)

Front Panel Touch Button Sensitivity

While holding down the “FUNCTION” button, press the C#7 or D7 key.

Using the +/- Keys to Raise or Lower the Setting Value by 1 (operation type B)

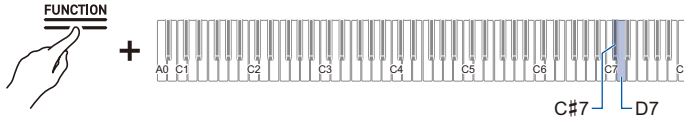

- Setting value: -1 (low sensitivity) to 0 (standard) to +1 (high sensitivity)
- Default value: 0

Key	Setting
C#7	Lowers touch button sensitivity by 1 (-)
D7	Raises touch button sensitivity by 1 (+)

Panel Lock

Setting [Panel Lock] to <Enabled> locks button operations*. When set to <Auto>, operation is automatically locked during performances only, preventing accidental operation during a performance.

* Excludes the power button and the disabling of Panel Lock.

While holding down the “FUNCTION” button, press the C8 key (Panel Lock).

Switching On/Off or Changing Setting Values Using a Single Key (operation type D)

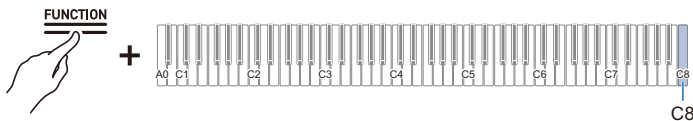

- Default value: Disabled

Setting Value	Notification Tone	Setting Details
Disabled	Tone for Off	Disables Panel Lock.
Enabled	1 notification tone	Enables Panel Lock.
Auto	2 notification tones	Locks operation only during performances.

Switching Panel Light Settings

While holding down the “FUNCTION” button, press the G7 key (Panel Light setting).

Switching On/Off or Changing Setting Values Using a Single Key (operation type D)

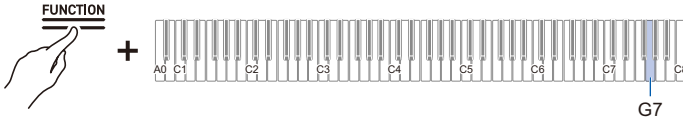

- Default value: 15 sec.

Setting Value	Notification Tone	Setting Details
Off	Tone for Off	Touch button light does not go off.
5 sec.	1 notification tone	When the set time elapses without a panel operation, all touch buttons turn off.
15 sec.	2 notification tones	
30 sec.	3 notification tones	
60 sec.	4 notification tones	
120 sec.	5 notification tones	

Notification Tone Volume

While holding down the “FUNCTION” button, press the A7 or B \flat 7 key.

Using the +/- Keys to Raise or Lower the Setting Value by 1 (operation type B)

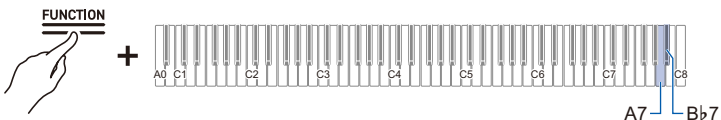

- Set value: 0 (silence) to 10 (maximum volume)
- Default value: 5

Key	Setting
A7	Lowers the notification tone volume by 1 (-)
B \flat 7	Raises the notification tone volume by 1 (+)
A7 + B \flat 7	Resets the notification tone volume to the default setting

Notification Tone Set Selection

You can choose your favorite notification tones from three different notification tone sets.

While holding down the “FUNCTION” button, press the B7 key (Notification Tone Set selection).

[Switching On/Off or Changing Setting Values Using a Single Key \(operation type D\)](#)

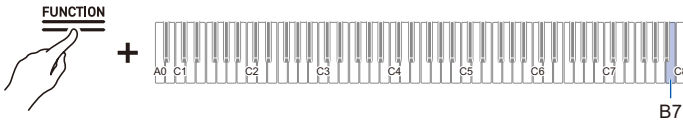

Volume Sync Equalizer

Automatically corrects the sound quality in response to the loud or quiet setting of the volume knob. Bass and treble will be heard clearly even at low volumes.

While holding down the “FUNCTION” button, press the F7 key (Volume Sync Equalizer).

[Switching On/Off or Changing Setting Values Using a Single Key \(operation type D\)](#)

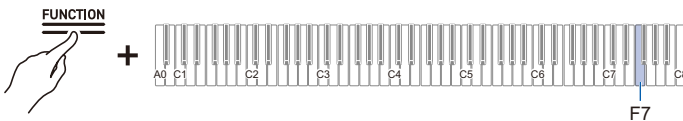

- Default value: Medium

Setting Value	Notification Tone	Setting Details
Off	Tone for Off	Does not compensate for sound quality.
Weak	1 notification tone	Weakly compensates for sound quality.
Medium	2 notification tones	Standard correction.
Strong	3 notification tones	Strongly compensates for sound quality.

Speaker Out

Set whether or not sound is emitted from the Digital Piano's speakers.

While holding down the “FUNCTION” button, press the E \flat 7 key (Speaker Out).

Switching On/Off or Changing Setting Values Using a Single Key (operation type D)

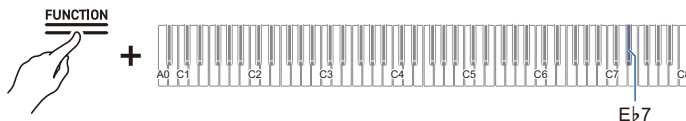

- Default value: Auto

Setting Value	Notification Tone	Setting Details
Disabled	Tone for Off	No sound is emitted from the Digital Piano's speakers.
Enabled	1 notification tone	Sound is emitted from the Digital Piano's speakers.
Auto	2 notification tones	When a plug is inserted into a PHONES jack, no sound is produced from the Digital Piano speakers. When no plug is inserted, sound is emitted from the Digital Piano.

Headphone Mode

When using headphones, this reproduces the natural sound that reaches your ears when you play an acoustic piano.

While holding down the “FUNCTION” button, press the E7 key (Headphone Mode).

Switching On/Off or Changing Setting Values Using a Single Key (operation type D)

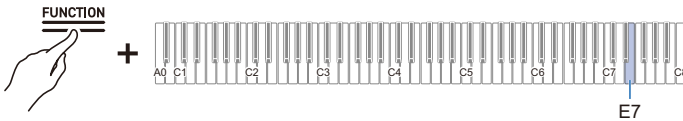

- Default value: On

Setting Value	Setting Details
Off	Turns off Headphone Mode.
On	Turns on Headphone Mode.

NOTE

- The Headphone Mode is turned On when a plug is inserted into one of the PHONES jacks.
- Regardless of the Headphone Mode setting, the sound output from the PHONES jacks is the same as the sound output from the LINE OUT jacks.

Troubleshooting

I cannot disable the Instant RePlayer.

Cause: [RePlayer/Recorder] is set to <Instant RePlayer>.

Solution: Switch the [RePlayer/Recorder] setting to something other than <Instant RePlayer> (such as <MIDI Recorder>).
For details on how to change the [RePlayer/Recorder] setting to <MIDI Recorder>, see [“Preparing to Use the MIDI Recorder”](#).

Touch buttons are not responding.

Cause:

- Gloved hands, fingernails, a stylus, etc. were used to touch the buttons.
- The touch button sensitivity setting is not appropriate.

Solution:

- Firmly touch the touch buttons with bare fingers.
- Change the touch button sensitivity setting. For more information, see [“When Touch Buttons Do Not Respond”](#).

No sound is produced when the keys are pressed.

Cause:

- The volume has been turned down with the volume knob.
- Headphones are connected. Or, a headphone conversion plug has been left in the PHONES jacks.
- The [Local Control] setting is turned <Off>.
- The [Speaker Out] setting is set to <Off>.

Solution:

- Turn the volume knob.
- Unplug the headphones or conversion plug from the PHONES jacks.
- Set the [Local Control] setting to <On>. For more information, see [“Local Control”](#).
- Set the [Speaker Out] setting to <Auto> or <On>. For more information, see [“Speaker Out”](#).

Sound is out of pitch.

Cause:

- The keyboard key tone (Transpose) has been changed from the default setting.
- The fine tuning (Tuning) setting for sound pitch is set to a frequency other than 440.0 Hz.
- Octave shift is set.
- Scale Tuning is set to something other than the equal temperament.

Solution:

- Reset [Transpose] to the default setting. Or, turn the power off and then back on. For details, see [“Changing the Pitch in Semitone Steps \(Transpose\)”](#).
- Set the [Tuning] setting to 440.0 Hz. Upper2 Detune: Lower Restore Detune to the default setting. For details, see [“Fine-tuning \(A-tuning\)”](#) and [“Fine-Tuning the Upper2 Part \(Upper2 Detune\)”](#), [“Fine-Tuning the Lower Part \(Lower Detune\)”](#) for more information.
- Set the Octave Shift setting to 0. For details, see [“Shifting by Octaves \(Octave Shift\)”](#).
- Set the Scale Tuning setting to equal Temperament.

Pressing the pedal has no effect.

Cause: The pedal cord is not properly connected to the PEDAL UNIT jack. Or, the plug connector is not completely plugged in.

Solution: Check that the pedal cord is properly connected and that the plug is firmly inserted into the jack.

Sound does not become stronger or weaker when I change the way I play (touch).

Cause: [Touch Response] is set to <Off>.

Solution: Set [Touch Response] to a setting other than <Off>. For details, see “[Changing the Volume Made by the Strength of Pressure Placed on a Key \(Touch Response\)](#)”.

The tone of the sound, effects, and so forth, do not change (i.e., the Digital Piano does not return to its default settings), even after turning the power off and back on again.

Cause: [Auto Resume] is set to <Enable>.

Solution: Switch [Auto Resume] to <Disabled> then turn the power off and back on again. For more information, see “[Saving the Digital Piano Settings \(Auto Resume\)](#)”.

Cannot send or receive MIDI when connected to a computer.

Solution:

- Check that the Digital Piano is properly connected to the computer with a USB cable, or that the correct is selected in the settings of the computer's music software.
- Turn off the power to this Digital Piano and close the music software on your computer, then turn on the power to this Digital Piano and restart the music software on your computer.

Some tones have the same timbre but slightly different sound quality and volume depending on keyboard position.

Cause: This is a boundary between sound ranges caused by electronic processing called digital sampling* and is not a malfunction.

* This process records the original sound of the instrument in multiple ranges, including low, mid, and high ranges, and creates a single tone in order to reproduce the sound quality of each range of the original instrument.

When pressing buttons, the sound that is being played is temporarily interrupted or the sound quality sounds slightly different.

Cause: When using Layer, Duet, playing a Built-in Song, or using the recording function, multiple parts sound simultaneously. If you press buttons in such a case, the tone-specific internal effect settings will be automatically changed, and depending on the part, this phenomenon may occur, but it is not a malfunction.

I don't know how to delete a User Song.





Solution: Deletion of User Songs can be executed from a smart device connected to the Digital Piano. For details, see the instructions for the dedicated app.
https://web.casio.com/app/en/music_space/manual/



I can't play songs recorded directly to a USB Flash Drive.



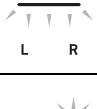



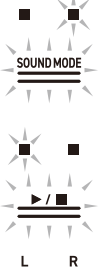
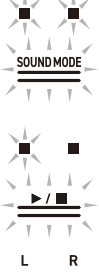

Solution: Try formatting the USB flash drive in exFAT format on your computer and then formatting it on the instrument. For more information, see “[Formatting a USB Flash Drive](#)”.



Error Display List

When an error occurs, the Visual Information Bar uses divided bars that blink alternately (error display). The touch buttons and indicators blink as shown in the illustration below.

Display	Cause	Solution
	<p>A USB flash drive is not properly inserted into the USB Type A port of the Digital Piano.</p>	<p>USB Type A Insert the USB flash drive correctly into the port.</p>
	<p>A USB flash drive was removed or inserted during operation.</p>	<p>Do not move USB flash drives while the Digital Piano is in operation.</p>
	<p>The USB flash drive is protected.</p>	<p>Cancel the protection of the USB flash drive.</p>
	<p>The USB flash drive contains antivirus software.</p>	<p>Use a USB Flash Drive that does not contain antivirus software.</p>
	<p>There are no files in the target folder that can be read or played.</p>	<p>Move the file you want to load or play to the target folder for loading. For details, refer to “Copying MIDI Song Data to a USB Flash Drive Using a Computer” and “Copying Audio Data (WAV, MP3) to a USB Flash Drive Using a Computer”.</p>
	<p>Tried to save data to a USB Flash Drive when there was no recorded data.</p>	<p>Record and then save.</p>

Display	Cause	Solution
 <p>L R</p>	<p>You are trying to save different data using the same name as a read-only file on the USB flash drive.</p>	<ul style="list-style-type: none"> • Rename the file on the USB flash drive before saving. • Remove the read-only attribute from the file on the USB flash drive and overwrite the file. • Use a different USB flash drive.
 <p>L R</p>	<p>Insufficient free space on USB flash drive.</p>	<ul style="list-style-type: none"> • Increase free space by deleting files stored on the USB flash drive. • Use a different USB Flash Drive.
 <p>L R</p>	<p>When recording with the Audio Recorder, an attempt was made to start recording beyond the maximum number of songs (99), or one of the following applies.</p> <ul style="list-style-type: none"> • Audio Recorder (USB Drv.): TAKE99.WAV or TAKE99.MP3 already exists in the AUDIOREC folder on the USB flash drive. • Audio Recorder (Internal): TAKE99.WAV or TAKE99.MP3 exists in the internal memory. 	<ul style="list-style-type: none"> • Audio Recorder (USB Drv.): Using a computer, move TAKE**.WAV(where ** = 01-99) or TAKE**.MP3 (where ** = 01-99) in the AUDIOREC folder of the USB flash drive to another folder or drive. • Audio Recorder (Internal): In internal memory. Delete TAKE**.WAV (where ** = 01-99) or TAKE**.MP3 (where ** = 01-99).
 <p>L R</p>	<p>You attempted to read or play a file in SMF format 2.</p>	<p>The SMF format that can be read and played back by this Digital Piano is "0" or "1".</p>

Display	Cause	Solution
  L R	<p>The size of the SMF file on the USB flash drive is too large to play on the Digital Piano.</p>	<p>This Digital Piano can play back SMF files up to a maximum size of approximately 320 KB.</p>
  L R	<p>Data on the USB flash drive is corrupted.</p>	<p>—</p>
  L R	<p>There is insufficient free memory space in the Digital Piano for converting MIDI recorder songs to SMF and saving them to a USB flash drive.</p>	<ul style="list-style-type: none"> • Reduce the data size of the song. • Erase data tracks that are not needed.
  L R	<p>The version of the file on the USB flash drive is not supported by the Digital Piano.</p>	<p>Prepare a version of the file that is supported by the Digital Piano.</p>

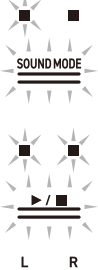
Display	Cause	Solution
	<p>The format of the USB flash drive is not compatible with this Digital Piano.</p>	<ul style="list-style-type: none"> • Use a computer or other device to change the USB flash drive to a format compatible with this Digital Piano. For more information, see “Formatting a USB Flash Drive”. • Use a different USB Flash Drive.
	<p>The USB flash drive is corrupted.</p>	<p>Use a different USB Flash Drive.</p>
	<p>The Wireless MIDI & audio adaptor is not inserted into the USB Type A port.</p>	<p>Insert the Wireless MIDI & audio adaptor into the USB Type A port.</p>

Other Information

Product Specifications

Model	AP-750BK/AP-750BN/AP-750WE/AP-750GB
Keyboard	88 keys
Settings	Hammer Response, Key-off Response
Duet	Changeable range (-2 to +2 octaves)
Transpose	-12 to 0 to +12 semitones
Octave Shift	-2 to 0 to +2 octaves
Sound source	
Number of tones	29 (28 tones for all keys + 1 bass tone for the lower part) + 10 classical piano repertoire tones <ul style="list-style-type: none"> • Layering possible (except for bass tone) • Splitting possible (bass tone only for the lower part)
Maximum Polyphony	256 notes
Touch Response function	5 sensitivity settings, Off
Tuning	415.5 Hz to 440.0 Hz to 465.9 Hz (in 0.1 Hz increments)
Temperament	Equal Temperament + 16 types
Piano Position	2 types
Acoustic Simulator	Key Off Simulator, String Resonance, Damper Resonance, Damper Noise, Open String Resonance, Aliquot Resonance, Pedal Action Noise, Key On Action Noise, Key Off Action Noise, Lid Simulator
Digital Effects	
Sound Mode Effects	Hall Simulator (8 types), Reverb (8 types), Surround (3 types)
Other Effects	Chorus (12 types), Brilliance (-12 to 0 to +12), Headphone Mode
Demo songs	3 songs
Music Library	
Built-in Songs	60 songs
User Songs	10 songs (max. approx. 320 KB per song, approx. 3.2 MB for 10 songs)*. * The stated capacity is the equivalent of 1 KB = 1024 bytes, 1 MB = 1024 ² bytes.
Song volume	Adjustable (also used for recording function)
Part On/Off	L, R

MIDI Recorder	Real-time recording and playback as MIDI data
Number of songs	1 song
Number of recording tracks	2 tracks
Capacity	Approximately 30,000 notes total
Recording Medium	Built-in flash memory
Song volume	Adjustable (also used for Music Library)
Instant RePlayer	Real-time recording and playback
Capacity	270 sec.
Recording Medium	Built-in flash memory
Controller	Specified number of return seconds/mark specified playback, stop
Song volume	Adjustable (also used for Music Library)
Audio Recorder	Real-time recording and playback as audio data
Number of songs	99 songs (files)
File format	Recording/Playback: WAV format (linear PCM, 16 bit, 44.1 kHz, stereo) Playback only: MP3 format (MPEG-1 Audio Layer 3, 32 to 320 kbps/variable bit rate (VBR) supported, 44.1 kHz / 48 kHz, mono/stereo)
Maximum recording time	Recording to USB flash drive: approx. 25 min. per track When recording to internal flash memory: approx. 18 min. (total of all songs)
Recording Medium	Built-in flash memory or USB flash drive
Metronome	
Beat bell	Off, 1-9 (beats)
Tempo range	20 to 255
Tempo Markings	9 types
Volume	Adjustable
Scene	Preset scenes (10 types), user scenes (up to 10 types)
Pedals	Damper (continuously variable), Sostenuto (Off, On), Soft (continuously variable)
Other Functions	<ul style="list-style-type: none"> • Auto Resume • Panel Lock • Notification Tone settings (switchable from set 1 to set 3, adjustable volume)
MIDI	16 ch multi-timbre reception

Input-Output Jacks	
PHONES jacks	Stereo standard phone jack (TRS phone) × 2
Power supply terminal	DC 24V
LINE OUT R, L/MONO jacks	Standard phone jack (TS phone) × 2 (Output impedance 470Ω, output voltage 1.7V (RMS) MAX)
USB ports	Type A, Type B
Pedal Unit jack	Special shape
Acoustics	
Amplifier output	10W × 2 + 10W × 2
Speakers	12cm × 4 + 3.5cm × 4
Power	AC adapter AD-E24250LW
Auto Power Off	Approx. 20 minutes, cancelable
Power Consumption	24V --- 24W
Size	Piano and Stand: W 140.1 × D 44.0 × H 92.9cm (55 3/16 × 17 5/16 × 36 9/16 inch)
Weight	Piano, Stand and Music Stand: approx. 53.6kg (118.2 lbs)

- In the interests of continued improvement, the specifications and design are subject to change without notice.

■ Optional Products

For more information on optional products, see "[Latest Support Information](#)".

■ About Music Score data

You can download music score data as a PDF file from the CASIO website. You will then be able to view music scores on your smart device. You can jump from the PDF file table of contents directly to the music score you want, and you can print out scores as needed.

Refer to "[Latest Support Information](#)" for music score PDF files.

Latest Support Information

<https://support.casio.com/global/en/emi/manual/AP-750/>



About the Contents of this Manual

- Unauthorized copying of this manual, in whole or in part, is prohibited. Note that copyright law prohibits the use of any other information without our permission, except for personal use.
- Be advised that we will not be liable for any loss, lost profits, or any claims from third parties resulting from the use of this manual or this device.
- The contents of this manual are subject to change without notice.
- Illustrations in this manual may differ from the actual product.

Trademarks and Registered Trademarks

- The Bluetooth® word mark and logos are registered trademarks owned by Bluetooth SIG, Inc. and any use of such marks by CASIO COMPUTER CO., LTD. is under license. Other trademarks and trade names are those of their respective owners.
- Company and product names used in this manual may be registered trademarks of others.

Operating Precautions

■ Environment

- Place the Digital Piano onto a stable and flat surface.
- To prevent the formation of mold, set up the product in a well-ventilated location where the temperature and humidity ranges shown below are maintained.
 - Recommended temperature range: 15 to 25°C
 - Recommended humidity range: 40 to 60% RH
- Do not set up the product in locations subject to extreme variations in temperature and/or humidity. Doing so can cause metal components to rust, coatings to degrade, and components to warp and split.

■ User Maintenance

- Wipe the product with a soft, dry cloth. Do not use a tissue, which can cause scratching.
- When soiling is more serious, moisten a soft cloth with a weak solution of water and a mild neutral detergent, wring out all excess moisture from the cloth, and then wipe the product. After that, wipe again with a separate soft dry cloth.
- Do not use any cleaning agents, chlorine disinfectants, sanitizing wipes, or other items that include benzene, organic solvents, alcohol, or other solvents for cleaning. Doing so can cause discoloration, deformation, paint peeling, cracking, etc.

■ Sterilization and Disinfection

- After wiping the product two or three times with a non-alcohol sanitizing wipe, use a soft, dry cloth to wipe it dry.
- Note that failure to wipe the product dry can cause streaks to remain.
- If the product is used by multiple parties, hand disinfection before each use is recommended.

■ Included and Optional Accessories

Use only accessories that are specified for use with this product. Use of unauthorized accessories creates the risk of fire, electric shock, and personal injury.

■ Weld Lines

Lines may be visible on the exterior of the product. These are “weld lines” that result from the plastic molding process. They are not cracks or scratches.

■ AC Adaptor Handling Precautions

- Never connect the AC adaptor (JEITA Standard, with unified polarity plug) that is specified with this Digital Piano to any other device besides this Digital Piano. Doing so creates the risk of malfunction.
- The AC adaptor cannot be repaired. If your AC adaptor malfunctions or becomes damaged, contact your original retailer or a CASIO Service Center.
- AC adaptor operating environment: Temperature: 0 to 40°C
Humidity: 10% to 90% RH
- Output polarity: 
- Use of a different type AC adaptor can cause smoking or malfunction.

■ About the panel

Operating the panel when it is dusty or dirty may scratch it.

Gently wipe the panel with a soft, clean cloth to remove dust and dirt before use.

Use your fingers to operate the panel. Using fingernails or sharp objects may scratch the surface.

■ Disconnect Protection Precautions

- (1) Never pull on the cord with excessive force.
- (2) Never repeatedly pull on the cord.
- (3) Never twist the cord at the base of the plug or connector.

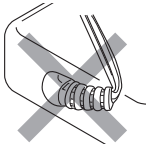

- (4) Loop and bundle the power cord, but never wind it around the AC adaptor.

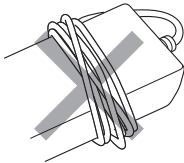

- (5) Before moving the Digital Piano, be sure to unplug the AC adaptor from the power outlet.

■ Locating the AC Adaptor for Use

- When using the AC adaptor, put in a location that satisfies the conditions below.
 - A location free of splashing liquids.
The AC adaptor is designed for indoor use only. Do not put it in a location where it may become wet and do not place a vase or any other container of liquid on top of it.
 - A location that is not humid.
 - A roomy, well ventilated location.
Do not cover the AC adaptor with newspaper, table cloth, curtain, or any other type of fabric.
 - Use a power outlet that is located near the Digital Piano.
This will let you immediately unplug from the power outlet should any problem occur.
- When using the AC adaptor, place it on the floor with its label surface downwards. The AC adaptor becomes prone to emitting electromagnetic waves when the label surface is facing upwards.

Various Lists

Tone List

Timbre Name	Selection Key Name	Input-Output		Input Only	
		Program Change	Bank Select MSB	Program Change	Bank Select MSB
BERLIN GRAND	C#3	0	16	0	0
BERLIN GRAND BRIGHT	D3	1	16	1	0
BERLIN GRAND MELLOW	Eb3	2	16	0	1
HAMBURG GRAND	E3	3	16	0	8
HAMBURG GRAND BRIGHT	F3	4	16	1	8
HAMBURG GRAND MELLOW	F#3	5	16	0	9
VIENNA GRAND	G3	6	16	0	12
VIENNA GRAND BRIGHT	Ab3	7	16	1	12
VIENNA GRAND MELLOW	A3	8	16	0	13
ROCK PIANO	Bb3	9	16	1	1
JAZZ PIANO	B3	10	16	0	2
BALLAD PIANO	C4	11	16	0	4
POP PIANO	C#4	12	16	1	2
DANCE PIANO	D4	13	16	1	4
HONKY-TONK PIANO	Eb4	14	16	3	0
PIANO PAD	E4	15	16	0	5
ELEC.PIANO	F4	16	16	4	0
60'S E.PIANO	F#4	17	16	4	1
DIGITAL E.PIANO 1	G4	18	16	5	0
DIGITAL E.PIANO 2	Ab4	19	16	5	1
HARPSICHORD	A4	20	16	6	0
VIBRAPHONE	Bb4	21	16	11	0
STRINGS 1	B4	22	16	49	0
STRINGS 2	C5	23	16	48	0
PIPE ORGAN	C#5	24	16	19	0
JAZZ ORGAN	D5	25	16	17	0
ELEC.ORGAN 1	Eb5	26	16	16	0
ELEC.ORGAN 2	E5	27	16	16	1
BASS (LOWER)	F5	28	16	32	0
SONATA GRAND	F#5	29	16	0	20
CONCERT ETUDE GRAND	G5	30	16	0	21
ETUDE GRAND	Ab5	31	16	0	22
PRELUDE GRAND	A5	32	16	0	23
ROMANCE GRAND	Bb5	33	16	0	24
PARTITA GRAND	B5	34	16	0	25
NOCTURNE GRAND	C6	35	16	0	26

Timbre Name	Selection Key Name	Input-Output		Input Only	
		Program Change	Bank Select MSB	Program Change	Bank Select MSB
WALTZ GRAND	C#6	36	16	0	27
POLONAISE GRAND	D6	37	16	0	28
LITTLE PIECE UPRIGHT	E♭6	38	16	0	29

BASS (LOWER) Key Map

Key	Sound
C-1 – G#0	Ghost Note
A0 – C5	Normal Finger w/ Off Noise
C#5 – G9	Harmonics

NOTE

- BASS (LOWER) is a tone for the bass section and cannot be sounded alone.
- BASS (LOWER) includes key ranges outside the range that can be played on the Digital Piano's keyboard. Keys outside the range can be played via external MIDI input.

Demo Song List

The length of a song may differ from its original.

Tone	Song Title
BERLIN GRAND	Widmung / R.A.Schumann=F.Liszt
HAMBURG GRAND	Étude Op.10-1 / F.F.Chopin
VIENNA GRAND	Duetto [Lieder Ohne Worte Heft 3] / F.Mendelssohn

Music Library List

Number	Selection Key Name	Song Title
1	C#3	Nocturne Op.9-2
2	D3	Fantaisie-Impromptu Op.66
3	Eb3	Étude Op.10-3 "Chanson de l'adieu"
4	E3	Étude Op.10-5 "Black Keys"
5	F3	Étude Op.10-12 "Revolutionary"
6	F#3	Étude Op.25-9 "Butterflies"
7	G3	Prélude Op.28-7
8	Ab3	Valse Op.64-1 "Petit Chien"
9	A3	Valse Op.64-2
10	Bb3	Moments Musicaux 3
11	B3	Impromptu Op.90-2
12	C4	Marche Militaire 1 (Duet)
13	C#4	Frühlingslied [Lieder Ohne Worte Heft 5]
14	D4	Fröhlicher Landmann [Album für die Jugend]
15	Eb4	Von fremden Ländern und Menschen [Kinderszenen]
16	E4	Träumerei [Kinderszenen]
17	F4	Tambourin
18	F#4	Menuet BWV Anh.114 [Clavierbüchlein der Anna Magdalena Bach]
19	G4	Inventio 1 BWV 772
20	Ab4	Inventio 8 BWV 779
21	A4	Inventio 13 BWV 784
22	Bb4	Praeludium 1 BWV 846 [Das Wohltemperierte Klavier 1]
23	B4	Le Coucou
24	C5	Gavotte
25	C#5	Sonatina Op.36-1 1st Mov.
26	D5	Sonatine Op.20-1 1st Mov.
27	Eb5	Sonate K.545 1st Mov.
28	E5	Sonate K.331 3rd Mov. "Turkish March"
29	F5	Rondo K.485
30	F#5	Für Elise
31	G5	Marcia alla Turca
32	Ab5	Sonate Op.13 "Pathétique" 1st Mov.
33	A5	Sonate Op.13 "Pathétique" 2nd Mov.
34	Bb5	Sonate Op.13 "Pathétique" 3rd Mov.
35	B5	Sonate Op.27-2 "Moonlight" 1st Mov.
36	C6	Rhapsodie 2
37	C#6	Waltz Op.39-15 (Duet)
38	D6	Liebesträume 3
39	Eb6	Blumenlied

Number	Selection Key Name	Song Title
40	E6	La Prière d'une Vierge
41	F6	Csikos Post
42	F#6	Humoresque Op.101-7
43	G6	Melodie [Lyrische Stücke Heft 2]
44	A♭6	Sicilienne Op.78
45	A6	Berceuse [Dolly] (Duet)
46	B♭6	Arabesque 1
47	B6	La Fille aux Cheveux de Lin [Préludes]
48	C7	Passepied [Suite bergamasque]
49	C#7	Gymnopédie 1
50	D7	Je Te Veux
51	E♭7	Salut d'Amour
52	E7	The Entertainer
53	F7	Maple Leaf Rag
54	F#7	L'arabesque [25 Étüden Op.100]
55	G7	La Styrienne [25 Étüden Op.100]
56	A♭7	Ave Maria [25 Étüden Op.100]
57	A7	Le retour [25 Étüden Op.100]
58	B♭7	La chevaleresque [25 Étüden Op.100]
59	B7	No.13 [Études de Mécanisme Op.849]
60	C8	No.26 [Études de Mécanisme Op.849]

Preset Scene List

Number	Name	Contents	Song Title
1	Default	Factory default Berlin Grand tone setting	Nocturne Op.9-2
2	Chopin	Setting suitable for playing Romantic music such as that of Chopin, etc.	Walse Op.64-1 "Petit Chien"
3	Beethoven	Setting suitable for playing classical music such as that of Beethoven, etc.	Sonate Op.31-2 "Tempest" 3rd Mov.
4	Mozart	Setting suitable for playing light and beautiful music such as that of Mozart, etc.	Sonate K.331 3rd Mov. "Turkish March"
5	Debussy	Setting suitable for playing impressionist music such as that of Debussy, etc.	Arabesque 1
6	Liszt	Setting for virtuosic performances such as those of Liszt, etc.	Mephisto-Walzer 1
7	Satie	Setting suitable for playing modern and contemporary music such as that of Satie, etc.	Le Piccadilly (Marche)
8	Baroque	Setting suitable for playing music of the Baroque period such as that of J.S. Bach, etc.	Harmonious Blacksmith
9	Lesson	Setting suitable for playing practice pieces, etc.	No.13 [Études de Mécanisme Op.849]
10	Concert	Setting suitable for practice for concerts, recitals, etc.	Étude Op.10-12 "Revolutionary"

List of User Scene Record Items

The setting items recorded in the user scene are as follows.

Function	Setting items
Tone	Tone Selection
	Layer ^{*1}
	Split ^{*1}
Duet	Duet Mode ^{*1}
	Duet left part octave ^{*1}
	Duet right part octave ^{*1}
Song Tempo	Tempo Value
Sound Mode Effects	Hall Simulator/Reverb on/off
	Surround on/off
	Hall Simulator/Reverb type ^{*2}
	Hall Simulator/Reverb depth ^{*2}
Chorus	Surround Type ^{*2}
	Chorus type ^{*2}
Brilliance	Brilliance

Function	Setting items
Acoustic Simulator	String Resonance ^{*3}
	Open String Resonance ^{*3}
	Aliquot Resonance ^{*3}
	Damper Resonance ^{*3}
	Damper Noise ^{*3}
	Key-on Action Noise ^{*3}
	Key-off Action Noise ^{*3}
	Pedal Action Noise ^{*3}
	Lid Simulator
Keyboard Touch	Touch Response
	Hammer Response
	Key Off Response
Pitch	Transpose
	A-tuning
	Upper1 Octave Shift
	Upper2 Octave Shift ^{*1}
Scale tuning	Fundamental tone of the tuning
	Tuning Type
	Stretch Tuning
Other settings	Upper1 Volume ^{*1}
	Upper2 Volume ^{*1}
	Upper2 Detune ^{*1}
	Upper2 Damper ^{*1}
	Lower Volume ^{*1}
	Lower Detune ^{*1}
	Lower Damper ^{*1}
	Keyboard volume ^{*1}
	MIDI song volume
	Audio Song Volume
Audio Song Center Cancel	

*1 Settings recorded in user scenes do not affect the playback of scene songs.

*2 If the scene song is a Music Library song, User Song or MIDI Recorder Song, the settings recorded in the user scene will be reflected in the scene song playback.

*3 If the scene song is a MIDI Recorder Song, its song data settings are reflected in the scene song playback.

Keyboard Function List

■ Set basic settings such as tuning

Hold down the “FUNCTION” button and select key.

	Note name	Assigned Function
A0	A0	Factory Reset
	B<0	Auto Power Off
C1	B0	disable/enable
	C1	Execution
	C#1	Wireless Audio Pairing
	D1	Wireless Function
	E#1	Off/On
	E1	Wireless MIDI & audio adaptor
	F1	Connection notification tone volume
	F#1	(-)
	G1	(+)
	A>1	Delete connection history
C2	A1	Save All Audio
	B>1	Load All Audio
	B1	Load SMF/MRF
	C2	Save SMF
	C#2	Save MRF
	D2	Delete SMF/MRF/Audio
	E>2	Format
	E2	Clear Audio
	F2	Clear All Audio
	F#2	Duet Mode
C3	G2	Off/On/Pan
	A#2	(-)
	A2	(+)
	B>2	Left-side keyboard Octave Shift
	B2	(-)
	C3	(+)
	C#3	Wireless Audio Volume
	D3	(-)
	E>3	(+)
	E3	Wireless Audio Center Cancel
C4	F3	disable/enable
	F#3	Audio Song Volume
	G3	(-)
	A>3	(+)
	A3	Audio Song Center Cancel
	B>3	Off/On
	B3	(-)
	C4	(+)
	C#4	MIDI Song Volume
	D4	(-)
C5	E>4	(+)
	E4	Keyboard Volume
	F4	(-)
	F#4	(+)
	G4	Instant RePlayer
	A>4	MIDI Recorder
	A4	Audio Recorder (USB Drv.)
	B>4	Audio Recorder with MIDI playback (USB Drv.)
	B4	Audio Recorder (Internal)
	C5	Audio Rec with MIDI playback (Internal)
C6	D5	Scale Tuning Selection
	E>5	Scale Tuning base note
	E5	Stretch Tuning
	F5	Off/On
	F#5	A-tuning
	G5	440.0 Hz
	A>5	442.0 Hz
	A5	-0.1 Hz
	B>5	+0.1 Hz
	B5	
C7	C#5	Display
	D5	Auto
	E>5	Metronome
	E5	Keyboard
	F5	Pedal
	F#5	Audio
	G5	Metronome Type
	A>5	1/2/3/4/5
	A5	Audio Illumination Type
	B>5	1/2/3/4
C8	B5	Brightness/Off
	C6	Off/1/2
	D6	
	E>6	Pedal
	E6	Half Pedal Position
	F6	(-)
	F#6	(+)
	G6	Local Control
	A>6	Off/On
	A6	Keyboard Channel
C9	B>6	(-)
	B6	(+)
	C7	Hi-Res Velocity MIDI OUT
	C#7	disable/enable
	D7	Touch Button Luminosity
	E>7	1/2
	E7	(-)
	F7	(+)
	F#7	Front Panel Touch Button Sensitivity
	G7	(-)
C10	A>7	(+)
	A7	Speaker Out
	B>7	disable/enable/Auto
	B7	Headphone Mode
	C8	Off/On
	C#8	Volume Sync Equalizer
	D8	Off/Weak/Normal/Strong
	E>8	Power On Alert
	E8	disable/enable
	F8	Panel Light setting
C11	G8	Off/5 sec./15 sec./30 sec./60 sec./120 sec.
	A>8	Auto Resume
	A8	disable/enable
	B>8	Notification Tone Volume
	B8	(-)
	C9	(+)
	C#9	Notification Tone Set selection
	D9	1/2/3
	E>9	Panel Lock
	E9	disable/enable/Auto

■ Change Sound Mode Effects and other settings

Hold down the “SOUND MODE” button and select key.

		Note name	Assigned Function	
A0		A0	Sound Mode Effects	Tone
		B♭0		Salon
C1		B0		N.Y. Club
		C1		Scoring Stage
	C♯1	Opera Hall		
	D1	Viennese Hall		
	E♭1	L.A. Hall		
	E1	Berlin Hall		
	F1	British Stadium		
	F♯1	Room 1		
	G1	Room 2		
	A♭1	Room 3		
	A1	Large Room		
	B♭1	Hall 1		
C2		B1		Hall 2
		C2		Hall 3
	C♯2	Stadium		
	D2	Hall Simulator/Reverb Type		
	E♭2	(-)		
	E2	(+)		
	F2	Wireless Audio Hall Simulator/Reverb depth		
	F♯2	(-)		
	G2	(+)		
	A♭2	Surround Type		
	A2	1		
	B♭2	2		
	B2	3		
C3		C3	Acoustic Simulator	Brilliance
		C♯3		(-)
	D3	(+)		
	E♭3	Tone		
	E3	Off		
	F3	(-)		
	F♯3	(+)		
	G3	Tone		
	A♭3	String Resonance		
	A3	Off		
	B♭3	(-)		
C4		B3		(+)
		C4		Tone
	C♯4	Off		
	D4	(-)		
	E♭4	(+)		
	E4	Tone		
	F4	Off		
	F♯4	(-)		
	G4	(+)		
	A♭4	Tone		
C5		A4	Open String Resonance	
		B♭4	Off	
	B4	(-)		
	C5	(+)		
	C♯5	Tone		
	D5	Off		
	E♭5	(-)		
	E5	(+)		
	F5	Tone		
	F♯5	Off		
	G5	(-)		
	A♭5	(+)		
C6		A5	Key On Action Noise	
		B♭5	Off	
	B5	(-)		
	C6	(+)		
	C♯6	Tone		
	D6	Off		
	E♭6	(-)		
	E6	(+)		
	F6	Tone		
	F♯6	Key Off Action Noise		
	G6	Off		
	A♭6	(-)		
	A6	(+)		
	B♭6	Lid Simulator		
	B6	Tone		
C7		C7	Chorus Type	Close
		C♯7		Semi
	D7	Full		
	E♭7	Removed		
	E7	Standard		
	F7	Wall		
	F♯7			
	G7			
	A♭7			
	A7			
	B♭7			
C8		B7		
		C8		
				Tone
				Chorus 1
				Chorus 2
			Chorus 3	
			Chorus 4	
			Feedback Chorus	
			Deep Chorus	
			Flanger 1	
			Flanger 2	
			Flanger 3	
			Flanger 4	
			Short Delay 1	
			Short Delay 2	

■ Change scene and metronome settings

Hold down the “SCENE” button and select key.

	Note name	Assigned Function
A0	A0	0
	B♭0	1
C1	B0	2
	C1	3
	C#1	4
	D1	5
	E♭1	6
	E1	7
	F1	8
	F#1	9
	G1	
	A♭1	
C2	A1	Metronome Volume
	B♭1	(-)
	B1	(+)
	C2	
	C#2	
	D2	Largo
	E♭2	Lento
	E2	Adagio
	F2	Andante
	F#2	Moderato
G2	Allargando	
A♭2	Allegro	
A2	Vivace	
B♭2	Presto	
C3	B2	Tap Tempo
	C3	Tempo Change
	C#3	(-)
	D3	(+)
	E♭3	Off
	E3	1 beat
	F3	2 beats
	F#3	3 beats
	G3	4 beats
	A♭3	5 beats
A3	6 beats	
B♭3	7 beats	
B3	8 beats	
C4	B3	9 beats
	C4	Store in User Scenes
	C#4	
	D4	
	E♭4	User Scene
	E4	1
	F4	2
	F#4	3
	G4	4
	A♭4	5
A4	6	
B♭4	7	
B4	8	
C5	C5	9
	C#5	10
	D5	
	E♭5	
	E5	Preset Scene
	F5	1
	F#5	2
	G5	3
	A♭5	4
	A5	5
B♭5	6	
B5	7	
C6	C6	8
	C#6	9
	D6	
	E♭6	
	E6	
	F6	
	F#6	
	G6	
	A♭6	
	A6	
B♭6		
B6		
C7	C7	
	C#7	
	D7	
	E♭7	
	E7	
	F7	
	F#7	
	G7	
	A♭7	
	A7	USB Flash Drive (User Scene)
B♭7	Save	
B7	Load	
C8	B7	Delete
	C8	USB Flash Drive (User Scene) Execution

Select a song

Hold down the “▶/■” button and select key.

Note name		Assigned Function	
A0	A0		0
	B♭0		1
C1	B0	Song selection using song number	2
	C1		3
	C♯1		4
	D1		5
	E♭1		6
	E1		7
	F1		8
	F♯1		9
	G1		
C2	A♯1		
	A1		
	B♭1	Song Playback Part selection	LR/LR
	B1		61 User 1
	C2		62 User 2
	C♯2		63 User 3
	D2	Music Library (User Song)	64 User 4
	E♭2		65 User 5
	E2		66 User 6
	F2		67 User 7
F♯2	68 User 8		
G2	69 User 9		
A♯2	70 User 10		
A2	MIDI Recorder Song		
B♭2	USB Flash Drive Song		
C3	B2	Song Select	(-)
	C3		(+)
	C♯3		1 Nocturne Op.9-2
	D3		2 Fantaisie-Impromptu Op.66
	E♭3		3 Etude Op.10-3 "Chanson de l'adieu"
	E3		4 Etude Op.10-5 "Black Keys"
	F3		5 Etude Op.10-12 "Revolutionary"
	F♯3		6 Etude Op.25-9 "Butterflies"
	G3		7 Prélude Op.28-7
	A♯3		8 Valse Op.64-1 "Petit Chien"
	A3		9 Valse Op.64-2
	B♭3		10 Moments Musicaux 3
	C4	B3	
C4			12 Marche Militaire 1 (Duet)
C♯4			13 Frühlingslied [Lieder Ohne Worte Heft 5]
D4			14 Fröhlicher Landmann [Album für die Jugend]
E♭4			15 Von fremden Ländern und Menschen [Kinderszenen]
E4			16 Träumerei [Kinderszenen]
F4			17 Tambourin
F♯4			18 Menuet BWV Anh.114 [Clavierbüchlein der Anna Magdalena Bach]
G4			19 Invention 1 BWV 772
A♯4			20 Invention 8 BWV 779
A4			21 Invention 13 BWV 784
B♭4			22 Præludium 1 BWV 846 [Das Wohltemperierte Klavier 1]
C5		B4	
	C5		24 Gavotte
	C♯5		25 Sonatine Op.36-1 1st Mov.
	D5		26 Sonatine Op.20-1 1st Mov.
	E♭5		27 Sonate K.545 1st Mov.
	E5		28 Sonate K.331 3rd Mov. "Turkish March"
	F5		29 Rondo K.485
	F♯5		30 Für Elise
	G5		31 Marcia alla Turca
	A♯5		32 Sonate Op.13 "Pathétique" 1st Mov.
	A5		33 Sonate Op.13 "Pathétique" 2nd Mov.
	B♭5		34 Sonate Op.13 "Pathétique" 3rd Mov.
	C6	B5	
C6			36 Rhapsodie 2
C♯6			37 Waltz Op.39-15 (Duet)
D6			38 Liebesträume 3
E♭6			39 Blumenlied
E6			40 La Prière d'une Vierge
F6			41 Calico Post
F♯6			42 Humoresque Op.101-7
G6			43 Melodie [Lyrische Stücke Heft 2]
A♯6			44 Sicilienne Op.78
A6			45 Berceuse [Dolly] (Duet)
B♭6			46 Arabesque 1
C7		B6	
	C7		48 Passepied [Suite bergamasque]
	C♯7		49 Gymnopédie 1
	D7		50 Je Te Veux
	E♭7		51 Salut d'Amour
	E7		52 The Entertainer
	F7		53 Maple Leaf Rag
	F♯7		54 L'arabesque [25 Etudes Op.100]
	G7		55 La Styrienne [25 Etudes Op.100]
	A♯7		56 Ave Maria [25 Etudes Op.100]
	A7		57 Le retour [25 Etudes Op.100]
	B♯7		58 La chevaleresque [23 Etudes Op.100]
	C8	B7	
C8			60 No.28 [Etudes de Mécanisme Op.849]

■ Start mark and start seconds for Instant RePlayer

Hold down the “▶/■” button and select key.

	Note name	Assigned Function	
		Replay start second count	Replay start mark
A0	A0	15 seconds back	
	B♭0		Most recent
C1	B0	20 seconds back	
	C1	25 seconds back	
	C♯1		1 time back
	D1	30 seconds back	
	E♯1		2 times back
	E1	35 seconds back	
	F1	40 seconds back	
	F♯1		3 times back
	G1	45 seconds back	
	A♭1		4 times back
	A1	50 seconds back	
	B♯1		5 times back
	B1	55 seconds back	
	C2	60 seconds back	
C2	C♯2		6 times back
	D2	65 seconds back	
	E♭2		7 times back
	E2	70 seconds back	
	F2	75 seconds back	
	F♯2		8 times back
	G2	80 seconds back	
	A♭2		9 times back
	A2	85 seconds back	
	B♭2		10 times back
	B2	90 seconds back	
	C3	95 seconds back	
C3	C♯3		11 times back
	D3	100 seconds back	
	E♯3		12 times back
	E3	105 seconds back	
	F3	110 seconds back	
	F♯3		13 times back
	G3	115 seconds back	
	A♭3		14 times back
	A3	120 seconds back	
	B♯3		15 times back
	B3	125 seconds back	
	C4	130 seconds back	
C4	C♯4		16 times back
	D4	135 seconds back	
	E♭4		17 times back
	E4	140 seconds back	
	F4	145 seconds back	
	F♯4		18 times back
	G4	150 seconds back	
	A♭4		19 times back
	A4	155 seconds back	
	B♭4		20 times back
	B4	160 seconds back	
	C5	165 seconds back	
C5	C♯5		21 times back
	D5	170 seconds back	
	E♯5		22 times back
	E5	175 seconds back	
	F5	180 seconds back	
	F♯5		23 times back
	G5	185 seconds back	
	A♭5		24 times back
	A5	190 seconds back	
	B♭5		25 times back
	B5	195 seconds back	
	C6	200 seconds back	
C6	C♯6		26 times back
	D6	205 seconds back	
	E♭6		27 times back
	E6	210 seconds back	
	F6	215 seconds back	
	F♯6	215 seconds back	28 times back
	G6	220 seconds back	
	A♭6		29 times back
	A6	225 seconds back	
	B♭6		30 times back
	B6	230 seconds back	
	C7	235 seconds back	
C7	C♯7		31 times back
	D7	240 seconds back	
	E♯7		32 times back
	E7	245 seconds back	
	F7	250 seconds back	
	F♯7		33 times back
	G7	255 seconds back	
	A♭7		34 times back
	A7	260 seconds back	
	B♭7		35 times back
	B7	265 seconds back	
	C8	270 seconds back	

Change tone and other settings

Hold down the “TONE” button and select key.

		Note name	Assigned Function		
A0		A0	Upper1 settings	Upper1 Volume	(-)
		B0			(+)
		B0		Upper1 Octave Shift	(-)
C1		C1	Transpose		(+)
		C#1			(-)
		D1	Touch Response	Off	
		E♭1		Light	
		E1		Medium light	
		F1		Normal	
		F#1		Medium heavy	
		G1		Heavy	
		A♭1		Tone	
		A1		Off	
C2		B♭1	Hammer Response		(-)
		B1			(+)
		C2	Key Off Response		
		C#2			
		D2		Tone	
		E♭2		Fast	
		E2		Normal	
		F2		Slow	
		F#2			
		G2			
C3		A♭2	Tone Selection		(-)
		A2			(+)
		B♭2		BERLIN GRAND	
		B2		BERLIN GRAND BRIGHT	
		C3		BERLIN GRAND MELLOW	
		C#3		HAMBURG GRAND	
		D3		HAMBURG GRAND BRIGHT	
		E♭3		HAMBURG GRAND MELLOW	
		E3		VIENNA GRAND	
		F3		VIENNA GRAND BRIGHT	
C4		F#3	Tone Selection	VIENNA GRAND MELLOW	
		G3		ROCK PIANO	
		A♭3		JAZZ PIANO	
		A3		BALLAD PIANO	
		B♭3		POP PIANO	
		B3		DANCE PIANO	
		C4		HONKY-TONK PIANO	
		C#4		PIANO PAD	
		D4		ELEC. PIANO	
		E♭4		60'S E. PIANO	
C5		E4	Tone Selection of Classical Piano Repertoire	DIGITAL E. PIANO 1	
		F4		DIGITAL E. PIANO 2	
		F#4		HARPSICHORD	
		G4		VIBRAPHONE	
		A♭4		STRINGS 1	
		A4		STRINGS 2	
		B♭4		PIPE ORGAN	
		B4		JAZZ ORGAN	
		C5		ELEC. ORGAN 1	
		C#5		ELEC. ORGAN 2	
C6		D5	Tone Selection of Classical Piano Repertoire	BASS (LOWER)	
		E♭5		SONATA GRAND	
		E5		CONCERT ETUDE GRAND	
		F5		ETUDE GRAND	
		F#5		PRELUDE GRAND	
		G5		ROMANCE GRAND	
		A♭5		PARTITA GRAND	
		A5		NOCTURNE GRAND	
		B♭5		WALTZ GRAND	
		B5		POLONAISE GRAND	
C7		C6	Layer settings	LITTLE PIECE UPRIGHT	
		C#6			
		D6		Layer	Off/On
		E♭6		Upper2 Volume	(-)
		E6			(+)
		F6		Upper2 Octave Shift	(-)
		F#6			(+)
		G6		Upper2 Detune	(-)
		A♭6			(+)
		A6		Upper2 Damper	disable/enable
C8		B♭6	Split settings	Lower Volume	(-)
		B6			(+)
		C7	Layer settings	Lower Detune	(-)
		C#7			(+)
		D7		Lower Damper	disable/enable
		E♭7			
		E7			
		F7			
		F#7			
		G7			
	A♭7				
	A7				

MIDI Implementation Chart

Model: AP-750

Version : 1.0

Function		Transmitted	Recognized	Remarks
Basic Channel	Default	1	1 - 16	
	Changed	1 - 16	1 - 16	
Mode	Default	Mode 3	Mode 3	
	Messages Altered	X * * * * *	X * * * * *	
Note Number		0 - 127	0 - 127	
	True voice	* * * * *	0 - 127*1	
Velocity	Note ON	O 9nH v = 1 - 127	O 9nH v = 1 - 127	
	Note OFF	O 8nH v = 0 - 127	O 9nH v = 0, 8nH v = 0 - 127	
After Touch	Key's	X	X	
	Ch's	X	O	
Pitch Bender		X	O	
Control Change	0, 32	O	O	Bank select LSB/MSB
	1	X	X	Modulation
	5	O	O	Portamento time
	6, 38	X*2	X*2	Data entry LSB/MSB
	7	O	O	Channel Volume
	10	X	X	Pan
	11	X	X	Expression
	64	X	X	Damper Pedal (Sustain)
	65	X	X	Portamento On/Off
	66	O	O	Sostenuto
	67	X	X	Soft pedal
	71	X	X	Filter resonance
	72	X	X	Release time
	73	X	X	Attack time
	74	X	X	Filter Cutoff Frequency
	76	X	X	Vibrato rate
	77	X	X	Vibrato depth
	78	X	X	Vibrato delay
	84	X	X	Portamento control
	86	O	O	High resolution velocity prefix
91	X	X	Reverb send level	
93	X	X	Chorus send level	
94	X	X	Delay send level	
100, 101	O*2	O*2	RPN LSB/MSB	
Program Change	True #	O * * * * *	O 0 - 127	
Exclusive		O*2	O*2	
System Common	Song Pos	X	X	
	Song Sel	X	X	
	Tune	X	X	
System Real Time	Clock	X	X	
	Commands	X	X	
Aux Messages	All sound off	X	O	
	Reset all controller	X	O	
	Local ON/OFF	X	X	
	All notes OFF	X	O	
	Active Sense	X	O	
	System Reset	X	X	
Remarks	<p>*1: Depends on tone. *2: For details about RPN and system exclusive messages, see MIDI Implementation at https://support.casio.com/global/en/emi/manual/AP-750/</p> <ul style="list-style-type: none"> The MIDI messages marked with "x" in the "Transmitted" column of the above chart may be output along with certain operations. 			

Mode 1 : OMNI ON, POLY
 Mode 3 : OMNI OFF, POLY

Mode 2 : OMNI ON, MONO
 Mode 4 : OMNI OFF, MONO

O : Yes
 X : No

CASIO®